

AI TAKAMUL COMPANY FOR ENGINEERING TESTS  
AND PROFESSIONAL SAFETY LIMITED

Basra, North Rumaila, Quality Control Yard - Iraq

Tel: +9647810009138 / +9647834964657

Email: OP@qualitycontrol-iraq.com / hany.akafi@qualitycontrol-iraq.com



**CERTIFICATE OF THOROUGH EXAMINATION & NDT FOR WIRE LINE  
CUTTER ASSEMBLY SR# 17122024**

Client	<b>HALLIBURTON</b>	Report No:	QC-24-12/HALL-WPS-/004
Item Description	Wire Line Cutter Assembly	Job No:	12-41-02-4C22
General Scope of Activity	Wire Line Cutter Assembly	Date of Inspection	17-DEC-2024
Place of Inspection	WPS Yard	Valid Until:	<b>16-JUNE-2025</b>
Reference Standards:	ASTM E709 & ASTM E 1444 (2016) ASME V Article 7 (2019), ASTM E165		

This is to certify that the undersigned did at the request of Halliburton, Al Burjesia Base attend their facilities at WPS Department on 14-MAY-2024 in order to carry out the scope of services as described below.

**1.0 Scope of Activity:**

- 1.1) Visual Inspection of Wire Line Cutter Assembly
- 1.2) Magnetic Particle Inspection (MPI).
- 1.3) Dye Penetrant Inspection (DPI)
- 1.4) Review of maintenance records and Previous reports
- 1.5) Issue of Report.

**2.0 Summary of Inspection:**

- 2.1) Thorough visual inspection of wire line cutter assembly was carried out and found satisfactory.
- 2.2) MPI was performed on wire line cutter assembly. The result was found satisfactory.
- 2.3) DPI was performed on wire line cutter assembly. The result was found satisfactory.
- 2.4) The maintenance record of the vehicle was reviewed.

**3.0 Identification of item(s) verified & Details of Inspection:**

**A) Wire Line Cutter Assembly**

serial number:	<b>17122024</b>
----------------	-----------------

**ALi Talib HB48903**

Date: 18/12/2024

Signature

Haliburton



AI TAKAMUL COMPANY FOR ENGINEERING TESTS  
AND PROFESSIONAL SAFETY LIMITED

Basra, North Rumaila, Quality Control Yard - Iraq

Tel: +9647810009138 / +9647834964657

Email: OP@qualitycontrol-iraq.com / hany.akafi@qualitycontrol-iraq.com



**CERTIFICATE OF THOROUGH EXAMINATION & NDT FOR WIRE LINE  
CUTTER ASSEMBLY SR# 17122024**

**3.1) Visual Inspection:**

- The visual inspection of the wire line cutter assembly were carried out as follows:
- The **wire line cutter assembly** were inspected for any visual damages, dents, cracks to the extent of accessibility. The results were satisfactory.

**FINAL RESULT: PASS**

**3.2) Magnetic Particle Inspection (MPI):**

**3.3) Dye Penetrant Inspection (DPI)**

Dye Penetrant Inspection was performed on the following components.:

Magnetic particle Inspection was performed on the following components.:

- **Wire Line Cutter Assembly**

**FINAL RESULT: PASS**

**3.4) Review of maintenance Record:**

The maintenance records and test reports were reviewed and found satisfactory

**FINAL RESULT: PASS**

**4.0 CONCLUSION:**

The above **wire line cutter assembly** was found to be in satisfactory condition after carrying out necessary inspection and tests subjected to proper maintenance according to manufacturer recommendation.

**ALI Talib HB48903**

**Date: 18/12/2024**

**Signature**

**Haliburton**



**AI TAKAMUL COMPANY FOR ENGINEERING TESTS  
AND PROFESSIONAL SAFETY LIMITED**

Basra, North Rumaila, Quality Control Yard - Iraq

Tel: +9647810009138 / +9647834964657

Email: OP@qualitycontrol-iraq.com / hany.akafi@qualitycontrol-iraq.com



**CERTIFICATE OF THOROUGH EXAMINATION & NDT FOR WIRE LINE  
CUTTER ASSEMBLY SR# 17122024**

15	-	M10 x 19mm BOLT
14	-	AIR HOSE - 100' - 150 PSI RATED
13	CR 400	FEMALE QUICK CONNECT - TO ATTACH TO PUMP
12	P-392	ENERPAC HAND PUMP
11	HC9250C	ENERPAC HOSE - $\Phi$ 1/4 - 50' W/ MALE QUICK CNCT
10	-	M10 NUT
9	HF0088	U BOLT - $\Phi$ 10mm x 75mcc
8	HF0086	CUTTER BRACE - WIRE LINE CUTTER ASSEMBLY
7	HF0085	GUIDE - ASSY - AIR LINE WIPER - W/ MODIFICATIONS
6	-	M10 LOCK WASHER
5	-	M10 x 25 mm BOLT
4	WHC 2000	ENERPAC CUTTER
3	HF0084	PLATE FOR WIRE LINE CUTTER - W.L. CUTTER ASSY
2	HF0083	CUTTER MOUNTING BRACKET - W.L. CUTTER ASSY
1	HF0082	BRACKET FOR LINER WIPER ASSEMBLY
0	HF0081	WIRE LINE CUTTER ASSEMBLY
ITEM NO.	PART OR IDENTIFYING #	NOMENCLATURE OR DESCRIPTION
PARTS LIST		

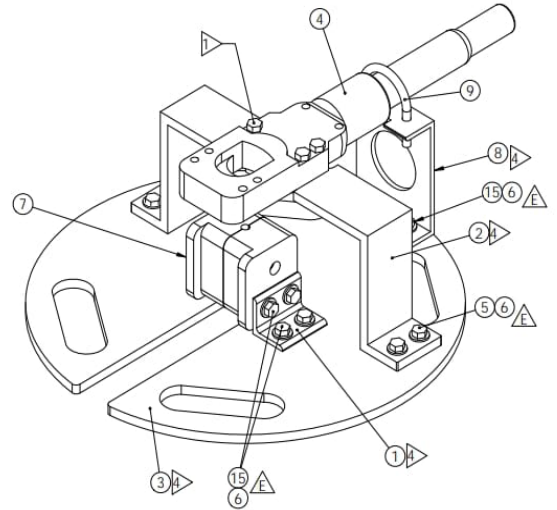

FROM HYD. CUTTER ASSY.  
IT.

WITH APPROPRIATE FASTENERS.  
OR EQUIV.

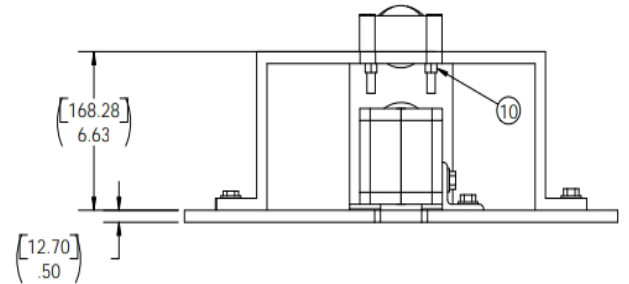
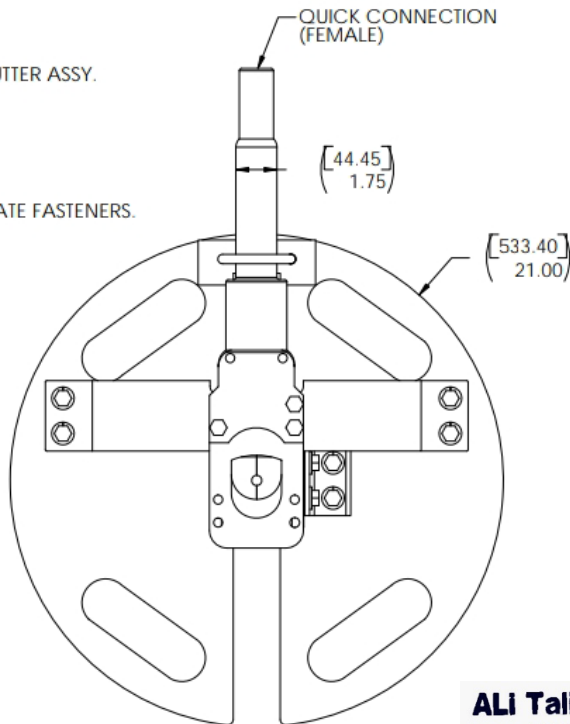

**ALI Talib HB48903**

Date: 18/12/2024

Signature   
Haliburton



AI TAKAMUL COMPANY FOR ENGINEERING TESTS  
AND PROFESSIONAL SAFETY LIMITED

Basra, North Rumaila, Quality Control Yard - Iraq

Tel: +9647810009138 / +9647834964657

Email: OP@qualitycontrol-iraq.com / hany.akafi@qualitycontrol-iraq.com



**CERTIFICATE OF THOROUGH EXAMINATION & NDT FOR WIRE LINE  
CUTTER ASSEMBLY SR# 17122024**

Client Name:	<b>HALLIBURTON</b>	Location:	WPS YARD	Job Number:	12-41-02-4C22
Date of Examination:	17-DEC-2024	Due Date:	<b>16-JUNE-2025</b>	Certificate No:	QC-24-12/HALL-WPS-004
serial number:	Item Description				Final Remarks
<b>17122024</b>	Wire Line Cutter Assembly				Satisfactory
Type of Inspection	Visual & Magnetic Particle Inspection				
Reference Standard	ASTM E709 & ASTM E 1444 (2016) ASME V Article 7 (2019)				

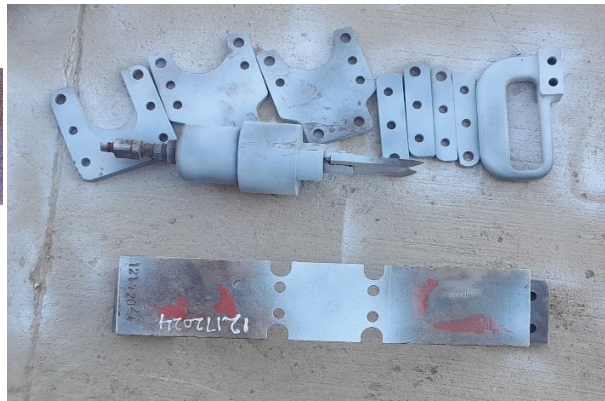

VISUAL, THOROUGH EXAMINATION	The above-mentioned equipment is visually inspected and found free from deformations, corrosion, and other defects.
MAGNETIC PARTICLE INSPECTION	M.P.I has been done on available critical areas and found free from cracks and other defects.
FINAL RESULTS	As per the client specification, the inspected areas were accepted at the time of inspection useable.

NDT Equipment Details					
Yoke	Permanent	Serial No:	PY-02	Due Date	11-04-2025
White Contrast	WCP-2	Batch No:	220602	Due Date	JUNE-2025
Black Ink	7HF	Batch No:	220605	Due Date	FEB-2025

ASNT Level II Inspector Name:	Reviewed By:	Signature & Stamp	Client Signature & Stamp
RAO SOHAIL	Hani Ali		<b>ALI Talib HB48903</b> Date: 18/12/2024 Signature Haliburton

REV:01 DATED 20 JUNE 2022



AI TAKAMUL COMPANY FOR ENGINEERING TESTS  
AND PROFESSIONAL SAFETY LIMITED

Basra, North Rumaila, Quality Control Yard - Iraq

Tel: +9647810009138 / +9647834964657

Email: OP@qualitycontrol-iraq.com / hany.akafi@qualitycontrol-iraq.com



**CERTIFICATE OF THOROUGH EXAMINATION & NDT FOR WIRE LINE  
CUTTER ASSEMBLY SR# 17122024**

Client Name:	<b>HALLIBURTON</b>	Location:	WPS YARD	Job Number:	12-41-02-4C22
Date of Examination:	17-DEC-2024	Due Date:	<b>16-JUNE-2025</b>	Certificate No:	QC-24-12/HALL-WPS-004
serial number:	Item Description				Final Remarks
<b>17122024</b>	Wire Line Cutter Assembly				Satisfactory
Type of Inspection	Visual & Dye Penetrant Inspection				
Reference Standard	ASTM E165				



TECHNICAL DETAILS	TECHNIQUE 2 - TYPE II VISIBLE, METHOD 'A' WATER -WASHABLE		
PENETRANT DWELL TIME:	30 minutes	DEVELOPER DWELL TIME:	15 minutes
Test Part Temperature:	65 °F	WHITE LIGHT INTENSITY:	3500 LUX
VISUAL, THOROUGH EXAMINATION	The above-mentioned equipment is visually Inspected and Found Free from Deformations, Corrosion, And Other Defects.		
DYE PENETRANT INSPECTION	D.P.I Has Been Done on Available Critical Areas and Found Free from Cracks and Other Defects.		
FINAL RESULTS	As Per the Client Specification, the Inspected Areas Was Accepted at The Time of Inspection Use able.		

NDT Equipment Details					
Equipment	COMPARATOR BLOCK	Serial No:	11223	Due Date	13,APR,2025
Equipment	Digital Lux Meter	Serial No:	2722003	Due Date	13,APR,2025
Equipment	INFRARED THERMOMETER	Serial No:	201704125	Due Date	13,APR,2025
Red Penetrant	Manufacture: Magnaflux	Batch No:	220511		May,2025
Developer	Manufacture: Magnaflux	Batch No:	220302		March,2025

ASNT Level II Inspector Name:	Reviewed By:	Signature & Stamp	Client Signature & Stamp
RAO SOHAIL	Hani Ali		<b>ALI Talib HB48903</b> Date: 18/12/2024 Signature Haliburton

REV:01 DATED 20 JUNE 2022

