



## Inspection Service

This Service Presented To

**Hong Hua**

Inspection Service:

Rig Lifting Gear:

Customer:

HONG HUA OIL & GAS Engineering Services Ltd,  
Iraq

Work Location:

HH – 29 / RU – 625

Inspection Date:

27 – Aug – 2024

Next Inspection Date:

26 – Feb – 2025

Inspector Name:

Syed Aamir Ali:

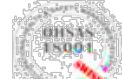



### Inspection Summary Report

Report No:	QC-HH29-08-24-0229	Job No:	QC-HH29-Aug-24-0229
Customer:	<b>HONG HUA OIL &amp; GAS Engineering Services Ltd, Iraq:</b>	Examination date:	27-Aug-2024
Location:	HH - 29 / RU - 625	Next Due date:	26-Feb-2025



Equipment Details:		
Name of The Examined Equipment:	Bow Shackles:	
<b>Summary of Procedures:</b>		
Description of Step:	Status	Remark
Visually Check For Any Damage Wear Distortion .....etc.	✓	Pass
Check The Marking of Serial Number:	✓	Pass
Check The Marking of Manufacture:	✓	Pass
Is This Equipment Safe To Operate:	✓	Pass
Is This Equipment Inspected Visually and Dimensionally:	✓	Pass
At The Time Of Inspection Found Satisfactory:	✓	Pass
Inspector Name & Qualification:	Signature & Stamp	
<b>Syed Aamir Ali:</b> ASNT Level II VT,MT,PT,UT, LEEA Level I,II		





## CERTIFICATE OF VISUAL AND THOROUGH EXAMINATION

This Certificate complies with the requirements of the Lifting Equipment Operations and Lifting Equipment Regulation

<b>Client Name:</b>	<b>HONG HUA OIL &amp; GAS Engineering Services Ltd, Iraq:</b>	Certificate No:	QC-HH-08-24-0229-001
Rig & Location:	HH – 29 / RU – 625	Job No:	QC-HH29-AUG-24-0229
Examination date:	27–Aug–2024	Next Due date:	26–Feb–2025

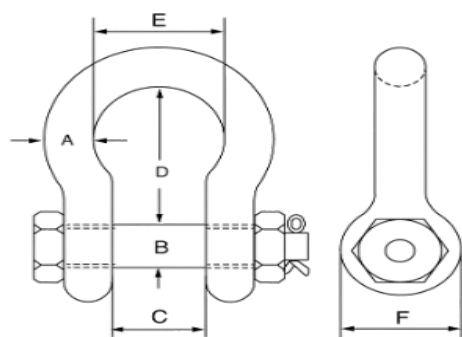
Serial Number:	QTY	Description:	SWL:	Date of Last Thorough Examination:
F 94 F 98 F 63 F 95 F 89 F 88 F 91 F 40 F 90 F 85	10	<p style="text-align: center;"><b><u>Bow Shackles</u></b> With HEX, Bolt, Nut, And Safety Cotter Pin:</p> <p><b>Manufacturer:</b> GT <b>Size:</b> 5/8” <b>Grade:</b> 6 <b>Safety Factor:</b> 6:1 <b>Location:</b> Rig Store</p> 	3 1/4 Ton	New

**Reference Standard:** BS EN 13889:2003 + A1:2008

Is This the First Examination After Installation or Assembly at a New Site or Location?	YES <input type="checkbox"/>	NO <input checked="" type="checkbox"/>	Was The Examination Carried out: Within an Interval of 6 Months? With an Interval of 12 Months? In Accordance with an Examination Scheme? After the Occurrence of Exceptional Circumstances?	YES <input checked="" type="checkbox"/>	NO <input type="checkbox"/>	YES <input type="checkbox"/>	NO <input checked="" type="checkbox"/>
If the answer to the above question is YES has the equipment been installed correctly?	YES <input checked="" type="checkbox"/>	NO <input type="checkbox"/>		YES <input checked="" type="checkbox"/>	NO <input type="checkbox"/>	YES <input type="checkbox"/>	NO <input checked="" type="checkbox"/>

Identification of any part found to have a defect which is or could not become a danger to persons and a description of the defect:  
(If none State NONE) **NONE**

Is the Above a Defect Which is of Immediate Danger to Persons: YES  NO

Is the Above an Affect Which is not yet but Could Become a Danger to Persons (If YES State the Date by When) YES by: \_\_\_\_\_

Particulars of any Repair, Renewal or Alteration Required to Remedy the Defect Identified Above:

Particulars of any tests Carried out as Part of the Examination: (If none state NONE)  
**The Items Were Inspected Visually and Dimensionally Where No Signs of Defects Were Observed at The Time of Inspection Found Satisfactory:**

Visual and Dimension Checks was Carried Out.	YES <input checked="" type="checkbox"/>	NO <input type="checkbox"/>	YES <input checked="" type="checkbox"/>	NO <input type="checkbox"/>
IS THIS EQUIPMENT SAFE TO OPERATE?	YES <input checked="" type="checkbox"/>	NO <input type="checkbox"/>	YES <input checked="" type="checkbox"/>	NO <input type="checkbox"/>

<b>ASNT Level II Inspector Name:</b>	<b>Authenticating This Report:</b>	<b>Signature &amp; Stamp:</b>
Syed Aamir Ali:	Mohamed Abdulla LEEA Registered Technician	

REV: 01 Dated: 20 June 2022

**THIS IS TO CERTIFY THAT;**  
A competent person did attend the above-mentioned owner’s work location on the date shown above and the equipment described in this report was tested & inspected as per the requirements of Lifting Operations Lifting Equipment Regulation “LOLER”. The result was found Satisfactory at the time of Inspection and considered Safe for Lifting.

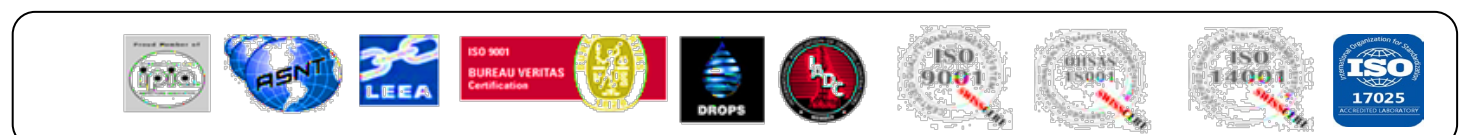



## CERTIFICATE OF VISUAL AND THOROUGH EXAMINATION

This Certificate complies with the requirements of the Lifting Equipment Operations and Lifting Equipment Regulation

<b>Client Name:</b>	<b>HONG HUA OIL &amp; GAS Engineering Services Ltd, Iraq:</b>	Certificate No:	QC-HH-08-24-0229-002
Rig & Location:	HH – 29 / RU – 625	Job No:	QC-HH29-AUG-24-0229
Examination date:	27–Aug–2024	Next Due date:	26–Feb–2025

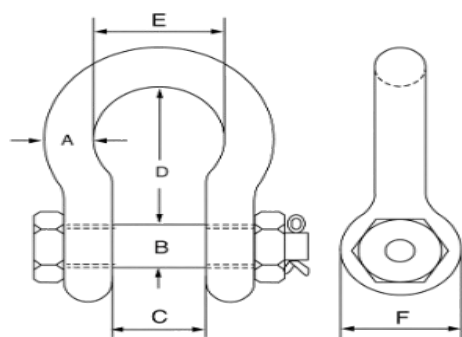
Serial Number:	QTY	Description:	SWL:	Date of Last Thorough Examination:
F 1 F 2 F 4 F 5 F 97 F 92 F 87 F 39 F 54 F 86	10	<p style="text-align: center;"><b><u>Bow Shackles</u></b> With HEX, Bolt, Nut, And Safety Cotter Pin:</p> <p><b>Manufacturer:</b> GT <b>Size:</b> 5/8” <b>Grade:</b> 6 <b>Safety Factor:</b> 6:1 <b>Location:</b> Rig Store</p> 	3 1/4 Ton	New

**Reference Standard:** BS EN 13889:2003 + A1:2008

Is This the First Examination After Installation or Assembly at a New Site or Location?	YES		NO	√	Was The Examination Carried out: Within an Interval of 6 Months?	YES	√	NO	
					With an Interval of 12 Months?	YES		NO	√
If the answer to the above question is YES has the equipment been installed correctly?	YES	√	NO		In Accordance with an Examination Scheme? After the Occurrence of Exceptional Circumstances?	YES	√	NO	
						YES		NO	√

Identification of any part found to have a defect which is or could not become a danger to persons and a description of the defect:  
(If none State NONE) **NONE**

Is the Above a Defect Which is of Immediate Danger to Persons: YES  NO

Is the Above an Affect Which is not yet but Could Become a Danger to Persons (If YES State the Date by When) YES by: \_\_\_\_\_

Particulars of any Repair, Renewal or Alteration Required to Remedy the Defect Identified Above:

Particulars of any tests Carried out as Part of the Examination: (If none state NONE)  
**The Items Were Inspected Visually and Dimensionally Where No Signs of Defects Were Observed at The Time of Inspection Found Satisfactory:**

Visual and Dimension Checks was Carried Out.	YES	√	NO	
IS THIS EQUIPMENT SAFE TO OPERATE?	YES	√	NO	

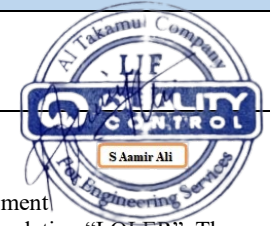
<b>ASNT Level II Inspector Name:</b>	<b>Authenticating This Report:</b>	<b>Signature &amp; Stamp:</b>
Syed Aamir Ali:	Mohamed Abdulla LEEA Registered Technician	

REV: 01 Dated: 20 June 2022

**THIS IS TO CERTIFY THAT;**

A competent person did attend the above-mentioned owner’s work location on the date shown above and the equipment described in this report was tested & inspected as per the requirements of Lifting Operations Lifting Equipment Regulation “LOLER”. The result was found Satisfactory at the time of Inspection and considered Safe for Lifting.

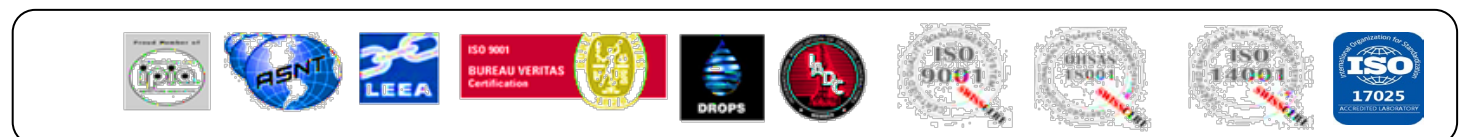



## CERTIFICATE OF VISUAL AND THOROUGH EXAMINATION

This Certificate complies with the requirements of the Lifting Equipment Operations and Lifting Equipment Regulation

<b>Client Name:</b>	<b>HONG HUA OIL &amp; GAS Engineering Services Ltd, Iraq:</b>	Certificate No:	QC-HH-08-24-0229-003
Rig & Location:	HH – 29 / RU – 625	Job No:	QC-HH29-AUG-24-0229
Examination date:	27–Aug–2024	Next Due date:	26–Feb–2025

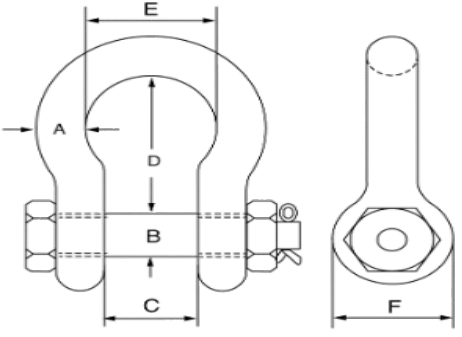
Serial Number:	QTY	Description:	SWL:	Date of Last Thorough Examination:
B 2 A 86 A 36 A 41 A 29 A 79 A 12 A 31 A 84 A 15 A 30 A 78 A 43 A 40	14	<b><u>Bow Shackles</u></b> <b>With HEX, Bolt, Nut, And Safety Cotter Pin:</b>  <b>Manufacturer:</b> GT <b>Size:</b> 1/2” <b>Grade:</b> 6 <b>Safety Factor:</b> 6:1 <b>Location:</b> Rig Store	 2 Ton	New

**Reference Standard:** BS EN 13889:2003 + A1:2008

Is This the First Examination After Installation or Assembly at a New Site or Location?	YES	NO	<input checked="" type="checkbox"/>	Was The Examination Carried out: Within an Interval of 6 Months? With an Interval of 12 Months? In Accordance with an Examination Scheme? After the Occurrence of Exceptional Circumstances?	YES	<input checked="" type="checkbox"/>	NO	<input type="checkbox"/>
If the answer to the above question is YES has the equipment been installed correctly?	YES	<input checked="" type="checkbox"/>	NO		YES	<input checked="" type="checkbox"/>	NO	<input type="checkbox"/>
					YES	<input type="checkbox"/>	NO	<input checked="" type="checkbox"/>

Identification of any part found to have a defect which is or could not become a danger to persons and a description of the defect:  
(If none State NONE) **NONE**

Is the Above a Defect Which is of Immediate Danger to Persons: YES  NO

Is the Above an Affect Which is not yet but Could Become a Danger to Persons (If YES State the Date by When) YES by: \_\_\_\_\_

Particulars of any Repair, Renewal or Alteration Required to Remedy the Defect Identified Above:

Particulars of any tests Carried out as Part of the Examination: (If none state NONE)

The Items Were Inspected Visually and Dimensionally Where No Signs of Defects Were Observed at The Time of Inspection Found Satisfactory:

Visual and Dimension Checks was Carried Out. YES  NO

IS THIS EQUIPMENT SAFE TO OPERATE? YES  NO

ASNT Level II Inspector Name:	Authenticating This Report:	Signature & Stamp:
Syed Aamir Ali:	Mohamed Abdulla LEEA Registered Technician	

REV: 01 Dated: 20 June 2022

**THIS IS TO CERTIFY THAT;**  
 A competent person did attend the above-mentioned owner’s work location on the date shown above and the equipment described in this report was tested & inspected as per the requirements of Lifting Operations Lifting Equipment Regulation “LOLER”. The result was found Satisfactory at the time of Inspection and considered Safe for Lifting.

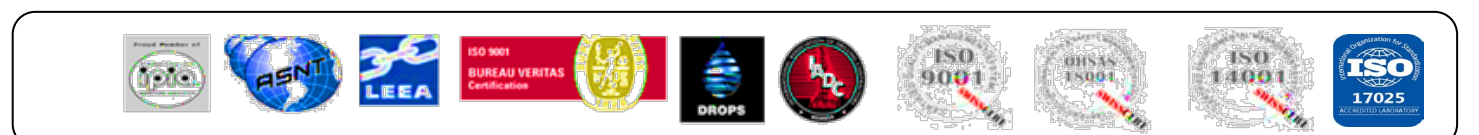



## CERTIFICATE OF VISUAL AND THOROUGH EXAMINATION

This Certificate complies with the requirements of the Lifting Equipment Operations and Lifting Equipment Regulation

<b>Client Name:</b>	<b>HONG HUA OIL &amp; GAS Engineering Services Ltd, Iraq:</b>	Certificate No:	QC-HH-08-24-0229-004
Rig & Location:	HH – 29 / RU – 625	Job No:	QC-HH29-AUG-24-0229
Examination date:	27–Aug–2024	Next Due date:	26–Feb–2025

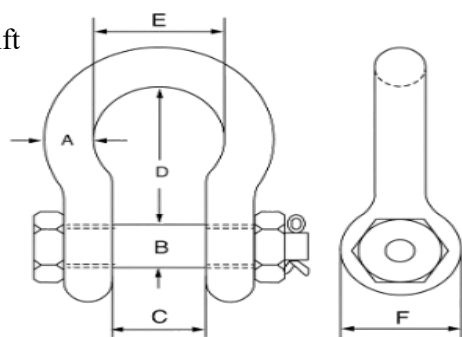
Serial Number:	QTY	Description:	SWL:	Date of Last Thorough Examination:
B 2693 B 2694 B 2688 B 2774 B 2677 B 2794	06	<p style="text-align: center;"><b><u>Bow Shackles</u></b> <b>With HEX, Bolt, Nut, And Safety Cotter Pin:</b></p> <p><b>Manufacturer:</b> Toyolift <b>Size:</b> 1/2” <b>Grade:</b> 6 <b>Safety Factor:</b> 6:1 <b>Location:</b> Rig Store</p> 	2 Ton	New

**Reference Standard:** BS EN 13889:2003 + A1:2008

Is This the First Examination After Installation or Assembly at a New Site or Location?	YES	<input type="checkbox"/>	NO	<input checked="" type="checkbox"/>	Was The Examination Carried out: Within an Interval of 6 Months?	YES	<input checked="" type="checkbox"/>	NO	<input type="checkbox"/>
					With an Interval of 12 Months?	YES	<input type="checkbox"/>	NO	<input checked="" type="checkbox"/>
If the answer to the above question is YES has the equipment been installed correctly?	YES	<input checked="" type="checkbox"/>	NO	<input type="checkbox"/>	In Accordance with an Examination Scheme? After the Occurrence of Exceptional Circumstances?	YES	<input checked="" type="checkbox"/>	NO	<input type="checkbox"/>
						YES	<input type="checkbox"/>	NO	<input checked="" type="checkbox"/>

Identification of any part found to have a defect which is or could not become a danger to persons and a description of the defect:  
(If none State NONE) **NONE**

Is the Above a Defect Which is of Immediate Danger to Persons: YES  NO

Is the Above an Affect Which is not yet but Could Become a Danger to Persons (If YES State the Date by When) YES by: \_\_\_\_\_

Particulars of any Repair, Renewal or Alteration Required to Remedy the Defect Identified Above:

Particulars of any tests Carried out as Part of the Examination: (If none state NONE)  
**The Items Were Inspected Visually and Dimensionally Where No Signs of Defects Were Observed at The Time of Inspection Found Satisfactory:**

Visual and Dimension Checks was Carried Out.	YES	<input checked="" type="checkbox"/>	NO	<input type="checkbox"/>
IS THIS EQUIPMENT SAFE TO OPERATE?	YES	<input checked="" type="checkbox"/>	NO	<input type="checkbox"/>

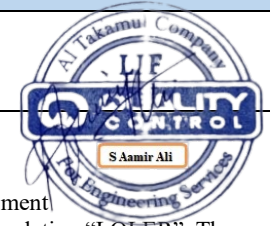
<b>ASNT Level II Inspector Name:</b>	<b>Authenticating This Report:</b>	<b>Signature &amp; Stamp:</b>
Syed Aamir Ali:	Mohamed Abdulla LEEA Registered Technician	

REV: 01 Dated: 20 June 2022

**THIS IS TO CERTIFY THAT;**

A competent person did attend the above-mentioned owner’s work location on the date shown above and the equipment described in this report was tested & inspected as per the requirements of Lifting Operations Lifting Equipment Regulation “LOLER”. The result was found Satisfactory at the time of Inspection and considered Safe for Lifting.

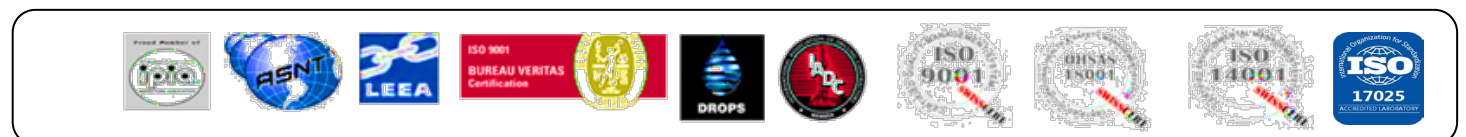



## CERTIFICATE OF VISUAL AND THOROUGH EXAMINATION

This Certificate complies with the requirements of the Lifting Equipment Operations and Lifting Equipment Regulation

<b>Client Name:</b>	<b>HONG HUA OIL &amp; GAS Engineering Services Ltd, Iraq:</b>	Certificate No:	QC-HH-08-24-0229-005
Rig & Location:	HH – 29 / RU – 625	Job No:	QC-HH29-AUG-24-0229
Examination date:	27–Aug–2024	Next Due date:	26–Feb–2025

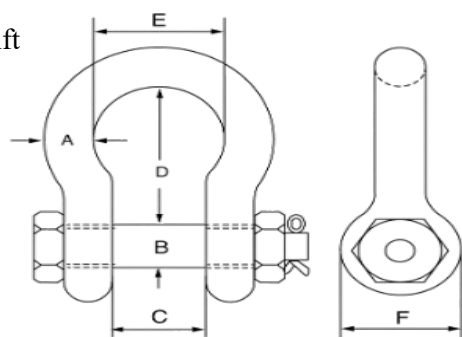
Serial Number:	QTY	Description:	SWL:	Date of Last Thorough Examination:
B 2967 B 2969	02	<p style="text-align: center;"><b><u>Bow Shackles</u></b> With HEX, Bolt, Nut, And Safety Cotter Pin:</p> <p><b>Manufacturer:</b> Toyolift <b>Size:</b> 1” <b>Grade:</b> 6 <b>Safety Factor:</b> 6:1 <b>Location:</b> Rig Store</p> 	8 1/2 Ton	Jan-2024

**Reference Standard:** BS EN 13889:2003 + A1:2008

Is This the First Examination After Installation or Assembly at a New Site or Location?	YES	<input type="checkbox"/>	NO	<input checked="" type="checkbox"/>	Was The Examination Carried out: Within an Interval of 6 Months?	YES	<input checked="" type="checkbox"/>	NO	<input type="checkbox"/>
					With an Interval of 12 Months?	YES	<input type="checkbox"/>	NO	<input checked="" type="checkbox"/>
If the answer to the above question is YES has the equipment been installed correctly?	YES	<input checked="" type="checkbox"/>	NO	<input type="checkbox"/>	In Accordance with an Examination Scheme? After the Occurrence of Exceptional Circumstances?	YES	<input checked="" type="checkbox"/>	NO	<input type="checkbox"/>
						YES	<input type="checkbox"/>	NO	<input checked="" type="checkbox"/>

Identification of any part found to have a defect which is or could not become a danger to persons and a description of the defect:  
(If none State NONE) **NONE**

Is the Above a Defect Which is of Immediate Danger to Persons: YES  NO

Is the Above an Affect Which is not yet but Could Become a Danger to Persons (If YES State the Date by When) YES by: \_\_\_\_\_

Particulars of any Repair, Renewal or Alteration Required to Remedy the Defect Identified Above: \_\_\_\_\_

Particulars of any tests Carried out as Part of the Examination: (If none state NONE)  
**The Items Were Inspected Visually and Dimensionally Where No Signs of Defects Were Observed at The Time of Inspection Found Satisfactory:**

Visual and Dimension Checks was Carried Out.	YES	<input checked="" type="checkbox"/>	NO	<input type="checkbox"/>
IS THIS EQUIPMENT SAFE TO OPERATE?	YES	<input checked="" type="checkbox"/>	NO	<input type="checkbox"/>

<b>ASNT Level II Inspector Name:</b>	<b>Authenticating This Report:</b>	<b>Signature &amp; Stamp:</b>
Syed Aamir Ali:	Mohamed Abdulla LEEA Registered Technician	

REV: 01 Dated: 20 June 2022

**THIS IS TO CERTIFY THAT;**  
A competent person did attend the above-mentioned owner’s work location on the date shown above and the equipment described in this report was tested & inspected as per the requirements of Lifting Operations Lifting Equipment Regulation “LOLER”. The result was found Satisfactory at the time of Inspection and considered Safe for Lifting.

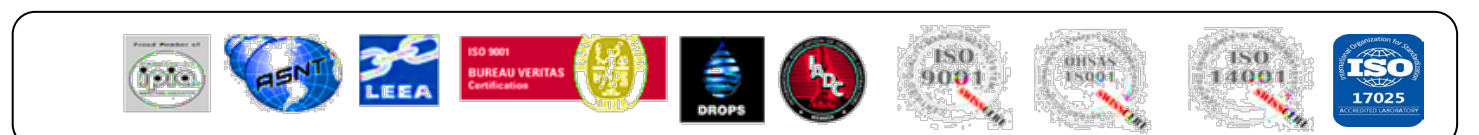



## CERTIFICATE OF VISUAL AND THOROUGH EXAMINATION

This Certificate complies with the requirements of the Lifting Equipment Operations and Lifting Equipment Regulation

<b>Client Name:</b>	<b>HONG HUA OIL &amp; GAS Engineering Services Ltd, Iraq:</b>	Certificate No:	QC-HH-08-24-0229-006
Rig & Location:	HH – 29 / RU – 625	Job No:	QC-HH29-AUG-24-0229
Examination date:	27–Aug–2024	Next Due date:	26–Feb–2025

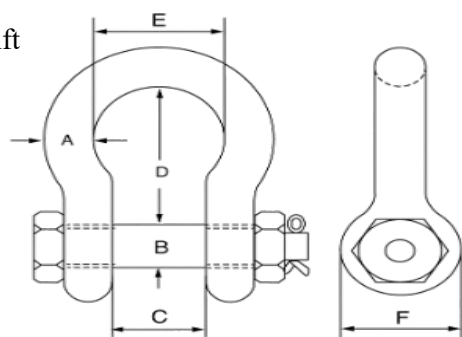
Serial Number:	QTY	Description:	SWL:	Date of Last Thorough Examination:
B 2933	01	<p style="text-align: center;"><b><u>Bow Shackles</u></b></p> <p style="text-align: center;"><b>With HEX, Bolt, Nut, And Safety Cotter Pin:</b></p> <p><b>Manufacturer:</b> Toyolift</p> <p><b>Size:</b> 7/8"</p> <p><b>Grade:</b> 6</p> <p><b>Safety Factor:</b> 6:1</p> <p><b>Location:</b> Rig Store</p> <div style="text-align: center;">  </div>	6 1/2 Ton	Jan-2024

**Reference Standard:** BS EN 13889:2003 + A1:2008

Is This the First Examination After Installation or Assembly at a New Site or Location?	YES	<input type="checkbox"/>	NO	<input checked="" type="checkbox"/>	Was The Examination Carried out: Within an Interval of 6 Months?	YES	<input checked="" type="checkbox"/>	NO	<input type="checkbox"/>
					With an Interval of 12 Months?	YES	<input type="checkbox"/>	NO	<input checked="" type="checkbox"/>
If the answer to the above question is YES has the equipment been installed correctly?	YES	<input checked="" type="checkbox"/>	NO	<input type="checkbox"/>	In Accordance with an Examination Scheme? After the Occurrence of Exceptional Circumstances?	YES	<input checked="" type="checkbox"/>	NO	<input type="checkbox"/>
						YES	<input type="checkbox"/>	NO	<input checked="" type="checkbox"/>

Identification of any part found to have a defect which is or could not become a danger to persons and a description of the defect:  
(If none State NONE) **NONE**

Is the Above a Defect Which is of Immediate Danger to Persons: YES  NO

Is the Above an Affect Which is not yet but Could Become a Danger to Persons (If YES State the Date by When) YES by: \_\_\_\_\_

Particulars of any Repair, Renewal or Alteration Required to Remedy the Defect Identified Above:

Particulars of any tests Carried out as Part of the Examination: (If none state NONE)  
**The Items Were Inspected Visually and Dimensionally Where No Signs of Defects Were Observed at The Time of Inspection Found Satisfactory:**

Visual and Dimension Checks was Carried Out.	YES	<input checked="" type="checkbox"/>	NO	<input type="checkbox"/>
IS THIS EQUIPMENT SAFE TO OPERATE?	YES	<input checked="" type="checkbox"/>	NO	<input type="checkbox"/>

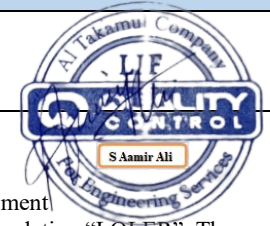
<b>ASNT Level II Inspector Name:</b>	<b>Authenticating This Report:</b>	<b>Signature &amp; Stamp:</b>
Syed Aamir Ali:	Mohamed Abdulla LEEA Registered Technician	

REV: 01 Dated: 20 June 2022

**THIS IS TO CERTIFY THAT;**

A competent person did attend the above-mentioned owner's work location on the date shown above and the equipment described in this report was tested & inspected as per the requirements of Lifting Operations Lifting Equipment Regulation "LOLER". The result was found Satisfactory at the time of Inspection and considered Safe for Lifting.

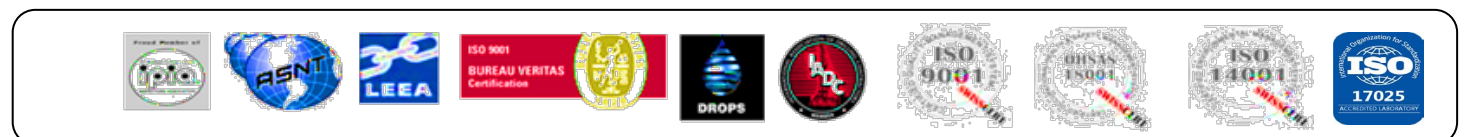



## CERTIFICATE OF VISUAL AND THOROUGH EXAMINATION

This Certificate complies with the requirements of the Lifting Equipment Operations and Lifting Equipment Regulation

<b>Client Name:</b>	<b>HONG HUA OIL &amp; GAS Engineering Services Ltd, Iraq:</b>	Certificate No:	QC-HH-08-24-0229-007
Rig & Location:	HH – 29 / RU – 625	Job No:	QC-HH29-AUG-24-0229
Examination date:	27–Aug–2024	Next Due date:	26–Feb–2025

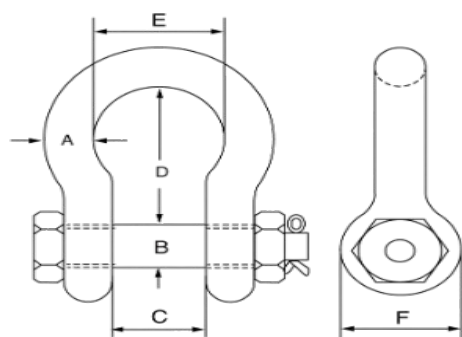
Serial Number:	QTY	Description:	SWL:	Date of Last Thorough Examination:
L 616	01	<p style="text-align: center;"><b><u>Bow Shackles</u></b></p> <p style="text-align: center;"><b>With HEX, Bolt, Nut, And Safety Cotter Pin:</b></p> <p><b>Manufacturer:</b> GT</p> <p><b>Size:</b> 7/8"</p> <p><b>Grade:</b> 6</p> <p><b>Safety Factor:</b> 6:1</p> <p><b>Location:</b> Rig Store</p> <div style="text-align: center;">  </div>	6 1/2 Ton	Jan-2024

**Reference Standard:** BS EN 13889:2003 + A1:2008

Is This the First Examination After Installation or Assembly at a New Site or Location?	YES <input type="checkbox"/>	NO <input checked="" type="checkbox"/>	Was The Examination Carried out: Within an Interval of 6 Months? With an Interval of 12 Months? In Accordance with an Examination Scheme? After the Occurrence of Exceptional Circumstances?	YES <input checked="" type="checkbox"/>	NO <input type="checkbox"/>	YES <input type="checkbox"/>	NO <input checked="" type="checkbox"/>
If the answer to the above question is YES has the equipment been installed correctly?	YES <input checked="" type="checkbox"/>	NO <input type="checkbox"/>		YES <input checked="" type="checkbox"/>	NO <input type="checkbox"/>	YES <input type="checkbox"/>	NO <input checked="" type="checkbox"/>

Identification of any part found to have a defect which is or could not become a danger to persons and a description of the defect:  
(If none State NONE) **NONE**

Is the Above a Defect Which is of Immediate Danger to Persons: YES  NO

Is the Above an Affect Which is not yet but Could Become a Danger to Persons (If YES State the Date by When) YES by: \_\_\_\_\_

Particulars of any Repair, Renewal or Alteration Required to Remedy the Defect Identified Above: \_\_\_\_\_

Particulars of any tests Carried out as Part of the Examination: (If none state NONE)  
**The Items Were Inspected Visually and Dimensionally Where No Signs of Defects Were Observed at The Time of Inspection Found Satisfactory:**

Visual and Dimension Checks was Carried Out.	YES <input checked="" type="checkbox"/>	NO <input type="checkbox"/>	YES <input checked="" type="checkbox"/>	NO <input type="checkbox"/>
IS THIS EQUIPMENT SAFE TO OPERATE?	YES <input checked="" type="checkbox"/>	NO <input type="checkbox"/>	YES <input checked="" type="checkbox"/>	NO <input type="checkbox"/>

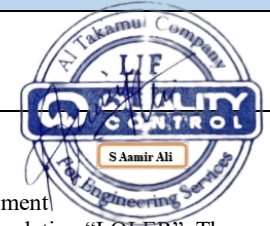
<b>ASNT Level II Inspector Name:</b>	<b>Authenticating This Report:</b>	<b>Signature &amp; Stamp:</b>
Syed Aamir Ali:	Mohamed Abdulla LEEA Registered Technician	

REV: 01 Dated: 20 June 2022

**THIS IS TO CERTIFY THAT;**

A competent person did attend the above-mentioned owner's work location on the date shown above and the equipment described in this report was tested & inspected as per the requirements of Lifting Operations Lifting Equipment Regulation "LOLER". The result was found Satisfactory at the time of Inspection and considered Safe for Lifting.

