

AI TAKAMUL COMPANY FOR ENGINEERING TESTS  
AND PROFESSIONAL SAFETY LIMITED

Basra, North Rumaila, Quality Control Yard - Iraq

Tel: +9647810009138 / +9647834964657

Email: OP@qualitycontrol-iraq.com / hany.akafi@qualitycontrol-iraq.com



**CERTIFICATE OF THOROUGH EXAMINATION & NDT FOR WIRE LINE  
CUTTER ASSEMBLY SR# 05042024**

Client	HALLIBURTON	Report No:	QC-24-SEP/HALL-WPS-/0010
Item Description	Wire Line Cutter Assembly	Job No:	QC-24-SEP/HALL -WPS-100
General Scope of Activity	Wire Line Cutter Assembly	Date of Inspection	Friday, 13 September 2024
Place of Inspection	WPS Yard	Valid Until:	Wednesday, March 12, 2025
Reference Standards:	ASTM E709 & ASTM E 1444 (2016) ASME V Article 7 (2019), ASTM E165		

This is to certify that the undersigned did at the request of Halliburton, Al Burjesia Base attend their facilities at WPS Department on **13-SEP-2024** in order to carry out the scope of services as described below.

**1.0 Scope of Activity:**

- 1.1) Visual Inspection of Wire Line Cutter Assembly
- 1.2) Magnetic Particle Inspection (MPI).
- 1.3) Dye Penetrant Inspection (DPI)
- 1.4) Review of maintenance records and Previous reports
- 1.5) Issue of Report.

**2.0 Summary of Inspection:**

- 2.1) Thorough visual inspection of wire line cutter assembly was carried out and found satisfactory.
- 2.2) MPI was performed on wire line cutter assembly. The result was found satisfactory.
- 2.3) DPI was performed on wire line cutter assembly. The result was found satisfactory.
- 2.4) The maintenance record of the vehicle was reviewed.

**3.0 Identification of item(s) verified & Details of Inspection:**

**A) Wire Line Cutter Assembly**

serial number:	05042024
----------------	----------

**ALI Talib HB48903**

Date: 14-SEP-2024

Signature   
Halliburton





## **CERTIFICATE OF THOROUGH EXAMINATION & NDT FOR WIRE LINE CUTTER ASSEMBLY SR# 05042024**

### **3.1) Visual Inspection:**

- The visual inspection of the wire line cutter assembly were carried out as follows:
- The **wire line cutter assembly** were inspected for any visual damages, dents, cracks to the extent of accessibility. The results were satisfactory.

**FINAL RESULT: PASS**

### **3.2) Magnetic Particle Inspection (MPI):**

### **3.3) Dye Penetrant Inspection (DPI)**

Dye Penetrant Inspection was performed on the following components.:

Magnetic particle Inspection was performed on the following components.:

- **Wire Line Cutter Assembly**

**FINAL RESULT: PASS**

### **3.4) Review of maintenance Record:**

The maintenance records and test reports were reviewed and found satisfactory

**FINAL RESULT: PASS**

### **4.0 CONCLUSION:**

The above **wire line cutter assembly** was found to be in satisfactory condition after carrying out necessary inspection and tests subjected to proper maintenance according to manufacturer recommendation.

**ALI Talib HB48903**

**Date: 14-SEP-2024**

**Signature**   
**Haliburton**



**AI TAKAMUL COMPANY FOR ENGINEERING TESTS  
AND PROFESSIONAL SAFETY LIMITED**

Basra, North Rumaila, Quality Control Yard - Iraq

Tel: +9647810009138 / +9647834964657

Email: OP@qualitycontrol-iraq.com / hany.akafi@qualitycontrol-iraq.com



**CERTIFICATE OF THOROUGH EXAMINATION & NDT FOR WIRE LINE  
CUTTER ASSEMBLY SR# 05042024**

15	-	M10 x 19mm BOLT
14	-	AIR HOSE - 100' - 150 PSI RATED
13	CR 400	FEMALE QUICK CONNECT - TO ATTACH TO PUMP
12	P-392	ENERPAC HAND PUMP
11	HC9250C	ENERPAC HOSE- Ø1/4 - 50' W/ MALE QUICK CNCT
10	-	M10 NUT
9	HF0088	U BOLT - Ø10m x 75mcc
8	HF0086	CUTTER BRACE - WIRE LINE CUTTER ASSEMBLY
7	HF0085	GUIDE - ASSY - AIR LINE WIPER - W/ MODIFICATIONS
6	-	M10 LOCK WASHER
5	-	M10 x 25 mm BOLT
4	WHC 2000	ENERPAC CUTTER
3	HF0084	PLATE FOR WIRE LINE CUTTER - W.L. CUTTER ASSY.
2	HF0083	CUTTER MOUNTING BRACKET - W.L. CUTTER ASSY.
1	HF0082	BRACKET FOR LINER WIPER ASSEMBLY
0	HF0081	WIRE LINE CUTTER ASSEMBLY
ITEM NO.	PART OR IDENTIFYING #	NOMENCLATURE OR DESCRIPTION
PARTS LIST		

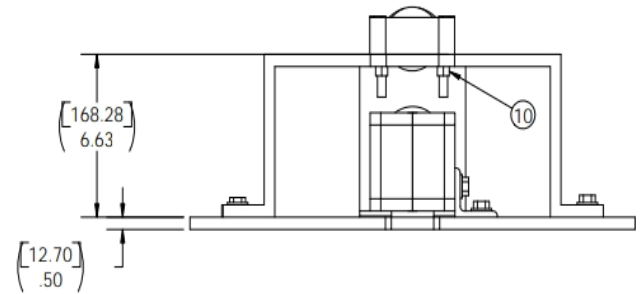
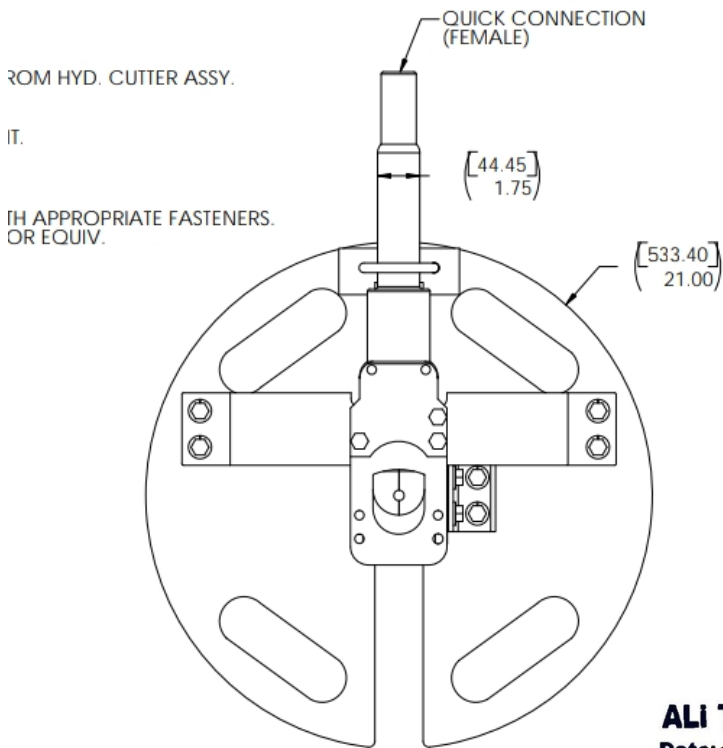
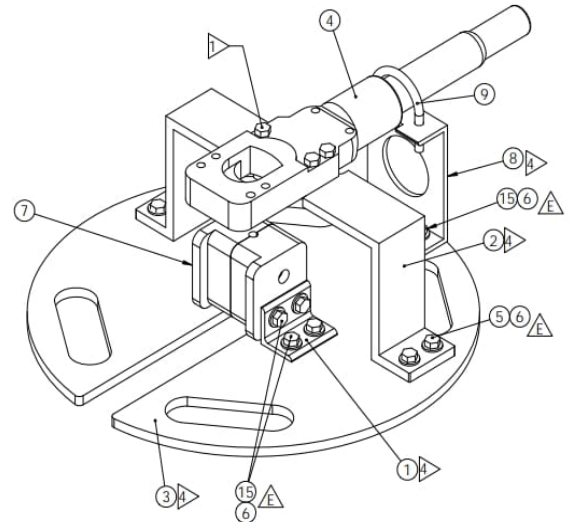

**ALI Talib HB48903**

Date: 14-SEP-2024

Signature *Ali Talib*  
Haliburton



**AI TAKAMUL COMPANY FOR ENGINEERING TESTS  
AND PROFESSIONAL SAFETY LIMITED**

Basra, North Rumaila, Quality Control Yard - Iraq

Tel: +9647810009138 / +9647834964657

Email: OP@qualitycontrol-iraq.com / hany.akafi@qualitycontrol-iraq.com



**CERTIFICATE OF THOROUGH EXAMINATION & NDT FOR WIRE LINE  
CUTTER ASSEMBLY SR# 05042024**

serial number:	Item Description	Final Remarks
<b>05042024</b>	Wire Line Cutter Assembly	Satisfactory
<b>Type of Inspection</b>	Visual & Magnetic Particle Inspection	
<b>Reference Standard</b>	ASTM E709 & ASTM E 1444 (2016) ASME V Article 7 (2019)	



<b>VISUAL, THOROUGH EXAMINATION</b>	The above-mentioned equipment is visually Inspected and Found Free from Deformations, Corrosion, And Other Defects.
<b>MAGNETIC PARTICLE INSPECTION</b>	
<b>MPI</b>	(Wet fluorescent inspection Thread & Body With ultraviolet light )
<b>FINAL RESULTS</b>	As Per the Client Specification, the Inspected Areas Was Accepted at The Time of Inspection Useable.

ASNT Level II Inspector Name:	Reviewed By:	Signature & Stamp	Client Signature & Stamp
M. Shahzad Ahmed	Hani Ali		<b>ALI Talib HB48903</b> Date: 14-SEP-2024 Signature Haliburton

REV:01 DATED 20 JUNE 2022



AI TAKAMUL COMPANY FOR ENGINEERING TESTS  
AND PROFESSIONAL SAFETY LIMITED

Basra, North Rumaila, Quality Control Yard - Iraq

Tel: +9647810009138 / +9647834964657

Email: OP@qualitycontrol-iraq.com / hany.akafi@qualitycontrol-iraq.com





**CERTIFICATE OF THOROUGH EXAMINATION & NDT FOR WIRE LINE  
CUTTER ASSEMBLY SR# 05042024**

serial number:	Item Description	Final Remarks
<b>05042024</b>	Wire Line Cutter Assembly	Satisfactory
Type of Inspection	Visual & Dye Penetrant Inspection	
Reference Standard	ASTM E165	

TECHNICAL DETAILS	TECHNIQUE 2 - TYPE II VISIBLE, METHOD 'A' WATER -WASHABLE		
PENETRANT DWELL TIME:	30 minutes	DEVELOPER DWELL TIME:	15 minutes
Test Part Temperature:	90 °F	WHITE LIGHT INTENSITY:	3525 LUX
VISUAL, THOROUGH EXAMINATION	The above-mentioned equipment is visually Inspected and Found Free from Deformations, Corrosion, And Other Defects.		
DYE PENETRANT INSPECTION	D.P.I Has Been Done on Available Critical Areas and Found Free from Cracks and Other Defects.		
FINAL RESULTS	As Per the Client Specification, the Inspected Areas Was Accepted at The Time of Inspection Use able.		

MPI & DPI NDT Equipment Details					
Equipment	AC YOKE	Serial No:	201504048	Cal Due Date	14-Oct-2024
Equipment	Digital Lux Meter	Serial No:	2722003	Cal Due Date	16-Oct-2024
Equipment	AC-Yoke Test Block	Serial No:	1657	Cal Due Date	14-Oct-2024
White Contrast WCP-2	Magnaflux	Batch No:	220602	Expiry Date:	JUN,2025
Black Ink 7HF	Magnaflux	Batch No:	220605	Expiry Date:	JULY.2025
White Light Intensity:	3630 lux	Magnetic Partial Concentration 7HF		1.2 to 2.4 ml/100 ml	
Equipment	COMPARATOR BLOCK	Serial No:	11223	Due Date	16-OCT-2024
Equipment	Digital Lux Meter	Serial No:	2722003	Due Date	16-OCT-2024
Equipment	INFRARED THERMOMETER	Serial No:	201704125	Due Date	16-OCT-2024
Red Penetrant	Manufacture: Magnaflux	Batch No:	220511	expire date	May,2025
Developer	Manufacture: Magnaflux	Batch No:	220302	expire date	March,2025

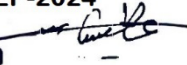
ASNT Level II / Inspector Name:	Reviewed By: NDT LEVEL II	Signature & Stamp	Client Signature & Stamp
USMAN BASHIS	HANY ALY 		<b>ALI Talib HB48903</b> Date:14-SEP-2024 Signature  Haliburton



Find Number Organization	Name / Rev Description	Drawing / Rev	Quantity	Reference Number
0001				
101320092 / A				
1.000	101320092	379605 BRACKET FOR LINE WIPER ASSEMBLY		
0002				
101320093 / A				
1.000	101320093	379605 CUTTER MOUNTING BRACKET LINER		
0003				
101320419 / A				
1.000	101320419	379605 PLATE, WIRELINE CUTTER LINER		
0004				
101320094 / D				
1.000	101320094	X11385 ENERPAC CUTTER		
0005				
101320095 / A				
10.000	101320095	379605 BOLT, M10 X 25MM, SS		
0006				
101320096 / A				
12.000	101320096	379605 WASHER, LOCK, M10 SS		
0007				
101320420 / A				
1.000	101320420	379605 LINE WIPER GUIDE WITH MODIFICATIONS		
0010				
101320101 / A				
1.000	101320101	379605 CUTTER BRACE LINE WIPER ASSEMBLY		
0011				
101320421 / A				
1.000	101320421	379605 U BOLT, 10M DIA. X 72MCC WIRELINE		



**ALI Talib HB48903**

Date: 14-SEP-2024

Signature  
Haliburton

0012

101320422 / A

2.000 101320422 379605 NUT, M10 SS

0013

101320423 / B

1.000 101320423 X11385 HOSE, 1/4 DIA. X 50FT WITH MALE QUICK CONNECT

0014

101320424 / B

1.000 101320424 PUMP, HAND, HYDRAULIC, ENERPAC, P-392

0015

101320425 / B

1.000 101320425 X11385 FEMALE QUICK CONNECT, ENERPAC

0016

101320426 / A

1.000 101320426 379605 AIRHOSE 60FT 150 PSI

0017

101380366 / A

2.000 101380366 379605 BOLT, M10 X 20MM, SS



**ALI Talib HB48903**

Date: 14-SEP-2024

Signature   
Haliburton