

**AI TAKAMUL COMPANY FOR ENGINEERING TESTING AND PROFESSIONAL SAFETY LIMITED**

Basra, North Rumaila, Quality Control Yard - Iraq: Tel: +9647810009138 / +9647834964657  
 Email: OP@qualitycontrol-iraq.com / hany.akafi@qualitycontrol-iraq.com



**CERTIFICATE OF VISUAL AND MAGNETIC PARTICLE INSPECTION AND ULTRASONIC THICKNESS GAUGING**

THIS REPORT COMPLIES WITH RECOGNIZED INTERNATIONAL STANDARDS & TECHNICAL REQUIREMENTS

<b>CLIENT:</b>	<b>ZHONGMAN PETROLEUM AND NATURAL GAS GROUP. Co. Ltd. Iraq Branch</b>	<b>REPORT NO:</b>	QC-06-24-0190-HP-018
<b>RIG &amp; LOCATION:</b>	ZPEC - 25 / RU - 620	<b>JOB NO:</b>	QC-ZPEC-JUN-24-0190
<b>INSPECTION DATE:</b>	25-Jun-2024	<b>DUE DATE:</b>	ANNUAL INSPECTION
<b>UNIT NAME:</b>	HIGH-PRESSURE LINE STRATE JOINT ( Rig Mast )	<b>MFG SERIAL NO:</b>	HP - 29
<b>DESCRIPTION:</b>	4" X 5K	<b>SPECIFICATION:</b>	ASTM E 709 / ASTM E 797

**TYPE OF INSPECTION: VISUAL INSPECTION AND ULTRASONIC WALL THICKNESS MEASUREMENT**

**INSPECTION DETAILS:**

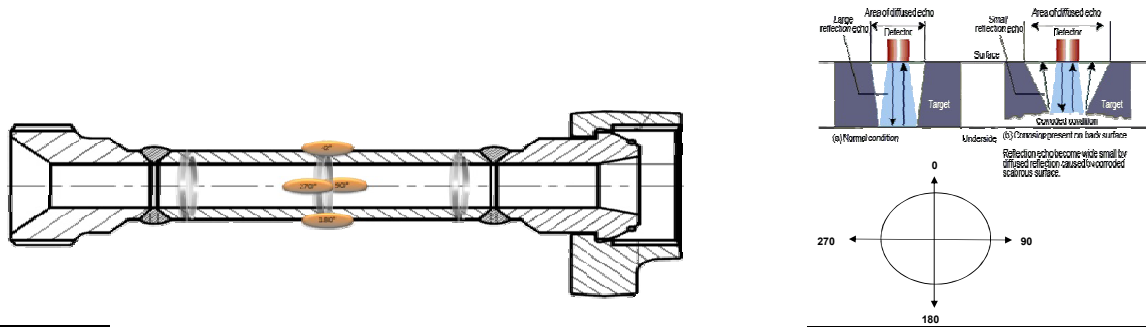

Online Traceability



A: 0° 12'O CLOCK / FORWARD  
 B: 90° 3'O 90° CLOCK / CENTER  
 C: 180° 6'O CLOCK / AFT  
 D: 270° 9'O CLOCK / PORT  
 \*\*\*ALL READINGS IN MM:  
 \*\*\*MINIMUM THICKNESS PROVIDED BY CLIENT:

ANGLE:	THICKNESS AT POSITION:				MIN: THICKNESS	REMARKS
	A	B	C	D		
0°	15.520	15.667	15.778	15.591	11.98 mm	Accepted
90°	15.840	15.987	15.752	15.451	11.98 mm	Accepted
180°	15.499	15.379	15.624	15.766	11.98 mm	Accepted
270°	15.301	15.655	15.455	15.842	11.98 mm	Accepted

**INSPECTION RESULT:**

<b>UT</b>	Accepted	***UT-The Above Item Was Found Acceptable As Per ASTM E 797 Acceptance Criteria and Also As Per Client Specification...
<b>MPI</b>	Accepted	*** MPI-The Above Item Weldment Area Had No Significant Discontinuous At The Time Of The Inspection And Was Found Acceptable in Accordance To ASTM E 709...

**Inspection Evaluation**

As Per OEM, The Readings Were Found Under The Acceptance Criteria At The Time of Inspection:

**INSPECTION EQUIPMENT DETAILS:**

<b>UT THICKNESS GAUGE:</b>	5500391	<b>CAL DUE DATE:</b>	14-Aug-2024
<b>UT Test Block:</b>	NoBo5087	<b>CAL DUE DATE:</b>	15-Aug-2024
<b>Permanent Hand Magnet:</b>	PY - 09	<b>CAL DUE DATE:</b>	15-Aug-2024
<b>White Contrast WPC-2 / Magnaflux:</b>	Batch No:220602	<b>EXPIRE DATE:</b>	Jun - 2025
<b>Black Ink 7HF / Magnaflux:</b>	Batch No:220605	<b>EXPIRE DATE:</b>	July - 2025

<b>PERSON DETAILS:</b>		<b>REVIEW BY:</b>		<b>CLIENT:</b>	
<b>INSPECTOR NAME:</b>	Syed Aamir Ali	<b>SENIOR INSPECTOR:</b>	Naveed Hussain	<b>CLIENT:</b>	ZPEC
<b>QUALIFICATION:</b>	ASNT LEVEL II VT,MT,PT,UT & LEEA III	<b>INSPECTION SUPERVISOR:</b>	Rao Suhail	<b>H B &amp; SIGNATURE:</b>	



Original - Client Files Copy - Area Office QC/FN/UT/077 Rev.00 Dated: 07 Nov - 2021

