

Safety Clamp CAT IV Inspection Certificate

Customer:	Hong Hua Oil & Gas Engineering Services, Lt	Date of Service:	14.07.2024
Location:	HH-29	Due Date	13.01.2025
Report No:	QC-HH-07-0200-01/04	Specification:	API RP 8B

PROCEDURE

Quantity:	01 Set
Equipment Name:	Safety Clamp
Serial No:	90549
Size:	6 ½" - 7 5/8"
Manufacturer:	JIANGSU RUTONG PETRO-MECHANICAL
Manufacturer Date :	2019.05
Standard:	API RP 8B
Frequency:	06 Month

The Rig was equipped with Safety Clamp the Following specification:

PROCEDURE

Safety Clamp was found fully installed condition for inspection. CAT IV Full inspection.

Safety Clamp Inspection Was Conducted as Per Standard.

Visually check the Safety Clamp for any damage, missing parts or cracks.

Dismantle the Safety Clamp as for possible into single components.

Visually checked for damage, deformations or cracks on the hinge's brackets, Safety Clamp segments with tail slot handles and hinge pin.

Visual & MPI was carried out as per manufacture recommendation of hanged connection body (inside & outside) handles guide halves Safety Clamp top cover halves etc.

Measure the wear of the hinge connection door & pin hole dovetail etc.

check the conditions & the content of the name plate or stamped parts

Check the parts after reassembled & repainted

Prepare & submitted the inspection report.

**** Visual and MPI Was Carried Out on the Available Critical Areas of the Safety Clamp and Found Satisfactory for Further Use.**

**** CAT IV Inspection Was Carried Out on Safety Clamp and Found Satisfactory at The Time of Inspection.**

-The products have been examined and found them conformable to relevant Quality standards and delivery is thus permitted

Inspector:	Jaafar Badr	Supervisor:	Ashraf Alsaid
Customer Reprehensive			



Safety Clamp CAT IV Inspection Certificate

Customer:	Hong Hua Oil & Gas Engineering Services, Lt	Date of Service:	14.07.2024
Location:	HH-29	Due Date	13.01.2025
Report No:	QC-HH-07-0200-01/04	Specification:	API RP 8B

PROCEDURE

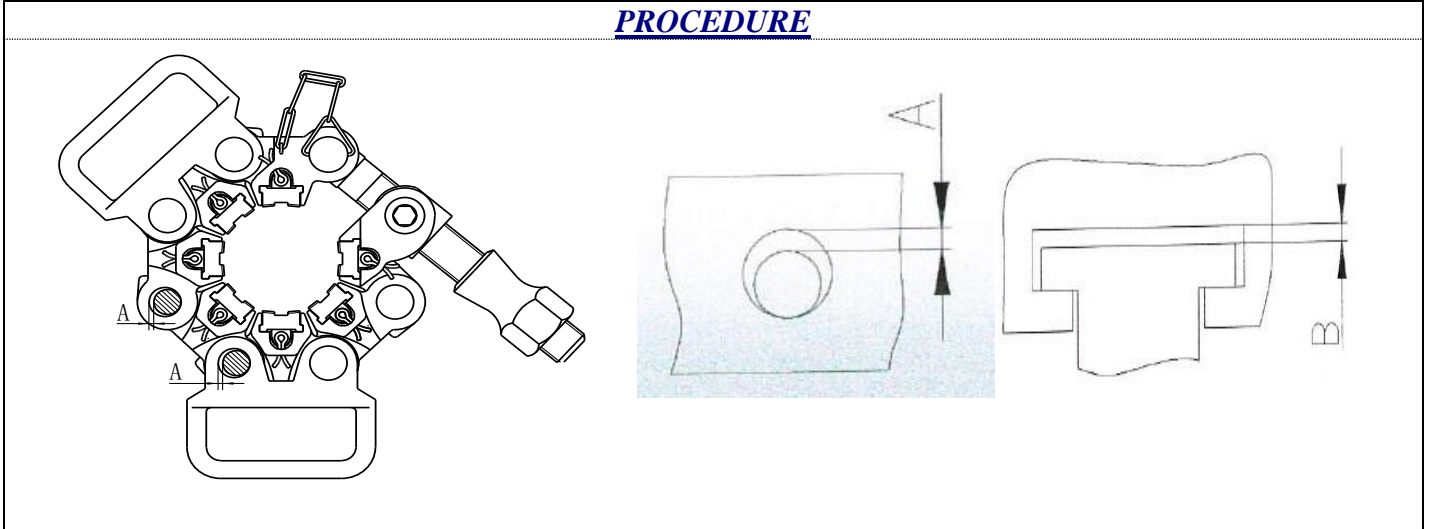

Description	Valued	OEM Valued	Result
Hinge Pin Hole Diameter	25.38 mm	Maximum 25.65 mm	<i>Accept</i>
Pin Diameter Of Main Hang	24.94 mm	Minimum 24.92 mm	<i>Accept</i>
The maximum Allowable Clearance Between Hinge Pin Hole and Pin (A)	0.35 mm	1.07 mm	<i>Accept</i>
The maximum Allowable Clearance Between The tooth plate and the groove bottom (B)	0.69 mm	Maximum 1.6 mm	<i>Accept</i>

Inspector:	Jaafar Badr	Supervisor:	Ashraf Alsaid
Customer Reprehensive			



Safety Clamp CAT IV Inspection Certificate

Customer:	Hong Hua Oil & Gas Engineering Services, Lt	Date of Service:	14.07.2024
Location:	HH-29	Due Date	13.01.2025
Report No:	QC-HH-07-0200-01/04	Specification:	API RP 8B

PICTORIAL



Inspector:	Jaafar Badr	Supervisor:	Ashraf Alsaid
Customer Reprehensive			

