



## ROTARY HAND SLIP DP 5" CAT IV INSPECTION REPORT

<b>Customer:</b>	<b>HONG HUA OIL &amp; GAS ENGINEERING SERVICES.</b>	<b>Date of inspection:</b>	<b>14-July-2024</b>
<b>Rig Name:</b>	<b>HH-29 / AS-67</b>	<b>Report No:</b>	<b>QC-HH-May-24-0203-012</b>
<b>Type of Inspection:</b>	<b>CAT IV Inspection.</b>	<b>Specification:</b>	<b>API RP 7L</b>

### PROCEDURE

**The Rig Was Equipped With 5" Drill Pipe Hand Slip The Following Specification:**

<b>QTY:</b>	1 (set)
<b>Equipment:</b>	5" ROTARY HAND SLIP DP
<b>Equipment SN#:</b>	2307399
<b>Manufacture:</b>	Jiangsu RYTONG PETRO Machinery Co., Ltd
<b>SIZE:</b>	5"
<b>Ref Standard:</b>	API RP 7L
<b>Next Examination:</b>	After 6 Month

**Remarks:**

CAT IV Inspection Was Carried Out on 5" ROTARY HAND SLIP DP and Found Accepted At The Time of Inspection:

<b>ASNT Level II Inspector Name:</b>	<b>Syed Aamir Ali</b>	<b>Supervisor:</b>	<b>NAVEED HUSSIEN</b>
--------------------------------------	-----------------------	--------------------	-----------------------

**Customer Reprehensive**





## ROTARY HAND SLIP DP 5" CAT IV INSPECTION REPORT

<b>Customer:</b>	<b>HONG HUA OIL &amp; GAS ENGINEERING SERVICES.</b>	<b>Date of inspection:</b>	<b>14-July-2024</b>
<b>Rig Name:</b>	<b>HH-29 / AS-67</b>	<b>Report No:</b>	<b>QC-HH-May-24-0203-012</b>
<b>Type of Inspection:</b>	<b>CAT IV Inspection.</b>	<b>Specification:</b>	<b>API RP 7L</b>

### PROCEDURE

The Products Have Been Inspected and Found Them Conformable to Relevant

The Rig was Equipped with Jiangsu RUTONG PETRO Machinery Co., Ltd SLIPS with following Specification

D.P SLIPS was found partly stripped down /assembled condition for CAT IV Inspection.	
Visually checked the slips for any damage, missing parts or cracks.	Performed
Dismantled the slips as for possible into single components.	Performed
For Rotary, Dc and DP Slips: Visually checked for damage, deformations or cracks on The hinges brackets, slips segments with tail slot handles and hinge pin	Performed
Perform MPI as Per the Manufacture Recommendation of Hanged Connection Body (inside & Outside) Handles Guide Halves Slips Top Cover Halves Etc...	Performed
Measured The Wear of the Hinge Connection Door & Pin Hole Dovetail Etc. As Per Manufactures Recommendation	Performed
Reassemble the Slips, Grease And Paint.	Performed
Checked the Condition and Contend of the Name Plate or Stamped Part.	Performed
Prepared And submitted the inspection report.	Performed

### PROCEDURE

\*\* Visual And MPI Was Carried Out on The Available Welding and Critical Areas of The D.P SLIPS and Found Satisfactory for Further Use.

**Remarks:**

CAT IV Inspection Was Carried Out on 5" ROTARY HAND SLIP DP and Found Accepted At The Time of Inspection:

<b>ASNT Level II Inspector Name:</b>	<b>Syed Aamir Ali</b>	<b>Supervisor:</b>	<b>NAVEED HUSSIEN</b>
--------------------------------------	-----------------------	--------------------	-----------------------

**Customer Reprehensive**





## ROTARY HAND SLIP DP 5" CAT IV INSPECTION REPORT

<b>Customer:</b>	<b>HONG HUA OIL &amp; GAS ENGINEERING SERVICES.</b>	<b>Date of inspection:</b>	<b>14-July-2024</b>
<b>Rig Name:</b>	<b>HH-29 / AS-67</b>	<b>Report No:</b>	<b>QC-HH-May-24-0203-012</b>
<b>Type of Inspection:</b>	<b>CAT IV Inspection.</b>	<b>Specification:</b>	<b>API RP 7L</b>

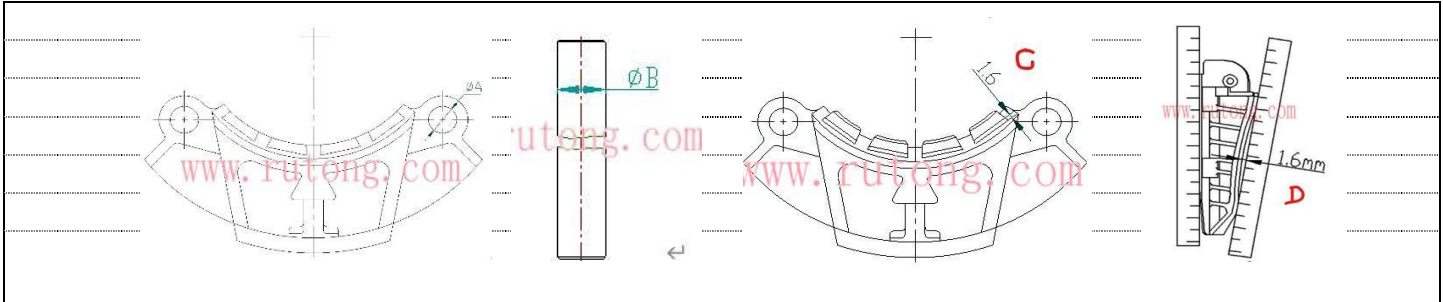

DESCRIPTION	ACTUAL VALUE	OEM VALUES MIN & MAX VALUE	RESULT
Diameter of the hole (A1)	24mm	Max 24.5mm	Qualified
Diameter of the pin (B1)	21.6mm	Min 21mm	Qualified
The gap between the back side of the dental	1.3mm	Max 1.6mm	Qualified
Slip body back cone wear value (D1)	0.9mm	1.6mm	Qualified
Diameter of the hole (A2)	23.8mm	Max 24.5mm	Qualified
Diameter of the pin (B2)	21.8mm	Min 21mm	Qualified
The gap between the back side of the dental	1.3mm	Max 1.6mm	Qualified
Slip body back cone wear value (D2)	0.8mm	1.6mm	Qualified
Diameter of the hole (A3)	23.9mm	Max 24.5mm	Qualified
Diameter of the pin (B3)	21.6mm	Min 21mm	Qualified
The gap between the back side of the dental	1.2mm	Max 1.6mm	Qualified
Slip body back cone wear value (D3)	1mm	1.6mm	Qualified

**Remarks:**

CAT IV Inspection Was Carried Out on 5" ROTARY HAND SLIP DP and Found Accepted At The Time of Inspection:

<b>ASNT Level II Inspector Name:</b>	<b>Syed Aamir Ali</b>	<b>Supervisor:</b>	<b>NAVEED HUSSIEN</b>
--------------------------------------	-----------------------	--------------------	-----------------------

**Customer Reprehensive**





## ROTARY HAND SLIP DP 5" CAT IV INSPECTION REPORT

<b>Customer:</b>	<b>HONG HUA OIL &amp; GAS ENGINEERING SERVICES.</b>	<b>Date of inspection:</b>	<b>14-July-2024</b>
<b>Rig Name:</b>	<b>HH-29 / AS-67</b>	<b>Report No:</b>	<b>QC-HH-May-24-0203-012</b>
<b>Type of Inspection:</b>	<b>CAT IV Inspection.</b>	<b>Specification:</b>	<b>API RP 7L</b>

### PICTORIAL



#### Remarks:

CAT IV Inspection Was Carried Out on 5" ROTARY HAND SLIP DP and Found Accepted At The Time of Inspection:

**ASNT Level II  
Inspector Name:**

**Syed Aamir Ali**



**Supervisor:**

**NAVEED HUSSIEN**

**Customer Reprehensive**

