



ELEVATOR LINK CAT IV SIX MONTH FULL INSPECTION CERTIFICATE

Customer:	HONG HUA OIL & GAS ENGINEERING SERVICES.	Date of Service:	14-July-2024
Location:	HH-29 / AS-67	RIG No.:	HH-29
Type Of Inspection:	CAT IV	P.O No.:	BY MAIL
Report No.:	QC-HH-May-24-0203-009	Speciation:	API RP 8B

PROCEDURE

QTY:	1 (set)
Equipment:	Elevator Link 500 Ton
Product Type:	HDDH 500 Ton
Equipment SN#:	18063, 18064
Manufacture:	Hong Hua oil Equipment Co. Ltd
Ref Standard:	API RP 8B
Date of Next Examination:	After 06 Month

**The Products Have Been Inspected and Found Them Conformable to Relevant:
The Rig was Equipped with Elevator Link the Following Specification:**

- 01- Visually Checked for the Serial Number & Manufacture Data plate.
- 02- Links Buffing & Cleaning Done As Per the Requirements of Qualified Inspector.
- 03- Visually Checked for Damage, Deformations or Cracks of The links:
- 04- Visual & MPI Checked for Whole Links, Measured the Eye Thickness for Wear.
- 05- Checked for The Measure Length & Checked The Straightness of The Links.
- 06- Down Grade The Links As Necessary According to the Measured Wear to the Maximum Load Limit:
- 07- Checked the Parts After Repainted.

INSPECTION RESULT

**** Visual & MPI was carried out on the available critical areas of the Elevator Links and found Accept at the time of inspection**

**** CAT IV Inspection was carried out on An Elevator Links & found satisfactory for further use**

Remarks:

Detailed reports are attached detailing all readings and results in -01 of 04- pages.

ASNT Level II Inspector Name:	Syed Aamir Ali		Supervisor:	Naveed Hussain
--------------------------------------	----------------	---	--------------------	----------------

Customer Reprehensive	:
------------------------------	---



ELEVATOR LINK CAT IV SIX MONTH FULL INSPECTION CERTIFICATE

Customer:	HONG HUA OIL & GAS ENGINEERING SERVICES.	Date of Service:	14-July-2024
Location:	HH-29 / AS-67	RIG No.:	HH-29
Type Of Inspection:	CAT IV	P.O No.:	BY MAIL
Report No.:	QC-HH-May-24-0203-009	Speciation:	API RP 8B

PROCEDURE

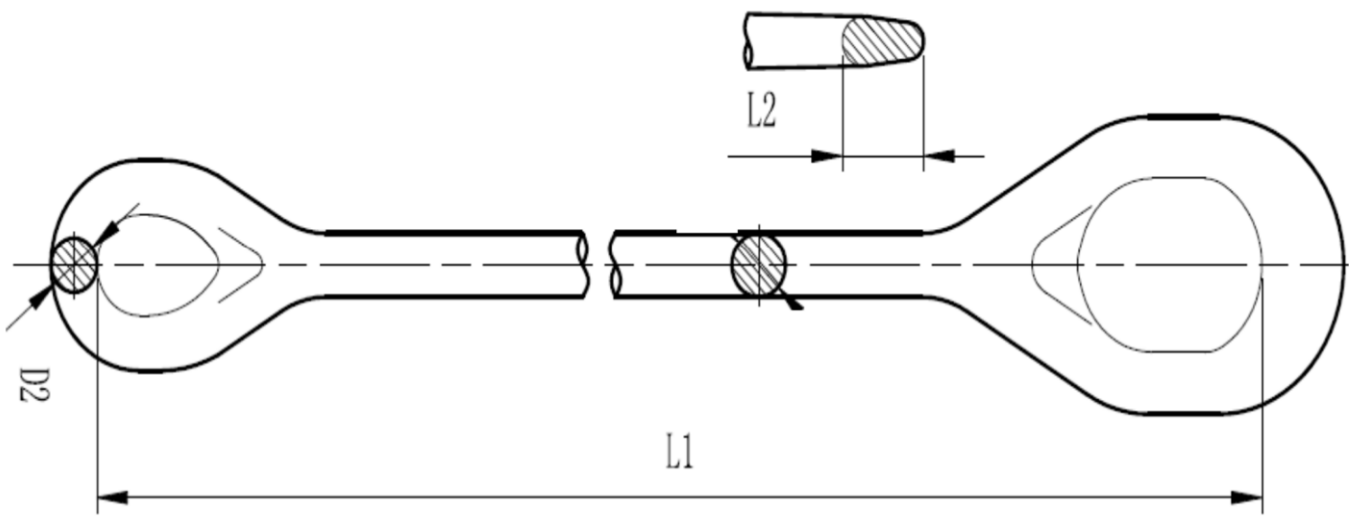

Model	L1 (mm)	L2 (mm)	D2 (mm)
DH500 size (mm)	4752 +200/-50	152 +5/-1.5	90+5/ 0
SN:18064	4780	152.1	90.1
SN:18063	4772	152.7	90.1
limit value	$L1-L1 = (-7 \sim +7)$	$L2 \geq 142$	$D2 \geq 82$
conclusion	Qualified	Qualified	Qualified

Remarks:

Detailed reports are attached detailing all readings and results in -02 of 04- pages.

PROCEDURE

ASNT Level II Inspector Name:	Syed Aamir Ali	Supervisor:	Naved Hussain
--------------------------------------	----------------	--------------------	---------------

Customer Reprehensive	:
------------------------------	---

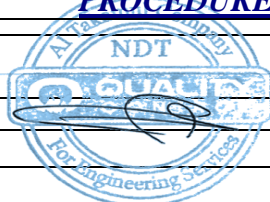



ELEVATOR LINK CAT IV SIX MONTH FULL INSPECTION CERTIFICATE

Customer:	HONG HUA OIL & GAS ENGINEERING SERVICES.	Date of Service:	14-July-2024
Location:	HH-29 / AS-67	RIG No.:	HH-29
Type Of Inspection:	CAT IV	P.O No.:	BY MAIL
Report No.:	QC-HH-May-24-0203-009	Speciation:	API RP 8B



Remarks:

Detailed reports are attached detailing all readings and results in -03 of 04- pages.

ASNT Level II Inspector Name:	Syed Aamir Ali	Supervisor:	Naveed Hussain
--------------------------------------	----------------	--------------------	----------------

Customer Reprehensive	:
------------------------------	---

