

**ELEVATOR 5 1/2" D/P CAT IV INSPECTION REPORT**

<b>Customer:</b>	Daqing Drilling Company	<b>Date of inspection:</b>	29-05-2024
<b>Rig Name:</b>	Rig (DQ -037)	<b>Report No:</b>	QC-DQ-05-24-0171-11
<b>Type of Inspection:</b>	CAT IV Inspection.	<b>Specification:</b>	<b>API RP 8B</b>

**PROCEDURE**

The Rig Was Equipped with Jiangsu RYTONG PETRO Machinery Co., LTD (ELEVATOR 5" D/P)

<b>QTY:</b>	1 (set)
<b>Equipment:</b>	ELEVATOR 4 1/2" D/P
<b>Product Type:</b>	DDZ 4 1/2" DDZ-350 (ton)
<b>SN:</b>	10408
<b>Manufacture:</b>	Jiangsu RYTONG PETRO Machinery Co., Ltd
<b>Date Of Manufacture:</b>	01.2011
<b>SIZE:</b>	4 1/2" DDZ-350
<b>Ref Standard:</b>	<b>API RP 8B</b>
<b>NEXT EXAMINATION:</b>	After 6 Month

**Remarks:**

CAT IV Inspection Was Carried Out on ELEVATOR D/P and Found Accepted at The Time of Inspection.

**Inspector:** Abdullah Mofeed

**Supervisor:** NAVEED HUSSIEN

**Customer Reprehensive**



**ELEVATOR 5 1/2" D/P CAT IV INSPECTION REPORT**

<b>Customer:</b>	Daqing Drilling Company	<b>Date of inspection:</b>	29-05-2024
<b>Rig Name:</b>	Rig (DQ -037)	<b>Report No:</b>	QC-DQ-05-24-0171-11
<b>Type of Inspection:</b>	CAT IV Inspection.	<b>Specification:</b>	<b>API RP 8B</b>

PROCEDURE

- The Products Have Been Inspected and Found Them Conformable to Relevant

The Rig was equipped with Jiangsu RUTONG PETRO Machinery Co., Ltd ELEVATOR with following specification

- ELEVATOR was found partly stripped down /assembled condition for CAT IV Inspection.

1- Visually Check for Any Damage Wear Distortion .....Etch.	Performed
2- Check Marking of Serial Number.	Performed
3- Clean the Weld Area from Any Rust Painting Using Grinder Brush.	Performed
4- Visual Examination for Weld Area.	Performed
5- Visual Examination for Critical Area	Performed
6- Apply White Contrast for Weld Area.	Performed
7- Apply White Contrast for Critical Area.	Performed
8- Perform MPI Using Permanent Magnet and Black Ink.	Performed
9- MPI Interpretation <b>API RP 8B</b> Acceptance Criteria.	Performed

PROCEDURE

\*\* Visual And MPI Was Carried Out on The Available Welding and Critical Areas of The ELEVATOR and Found Satisfactory for Further Use.

\*\* CAT IV Inspection Was Carried Out on ELEVATOR and Found Accepted at The Time of Inspection.

**Remarks:**

CAT IV Inspection Was Carried Out on ELEVATOR D/P and Found Accepted at The Time of Inspection.

**Inspector:**

Abdullah Mofeed

**Supervisor:**

NAVEED HUSSIEN

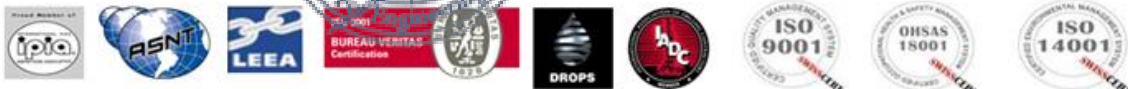
**Customer Reprehensive**



### ELEVATOR 5 1/2" D/P CAT IV INSPECTION REPORT

<b>Customer:</b>	Daqing Drilling Company	<b>Date of inspection:</b>	29-05-2024
<b>Rig Name:</b>	Rig (DQ -037)	<b>Report No:</b>	QC-DQ-05-24-0171-11
<b>Type of Inspection:</b>	CAT IV Inspection.	<b>Specification:</b>	API RP 8B

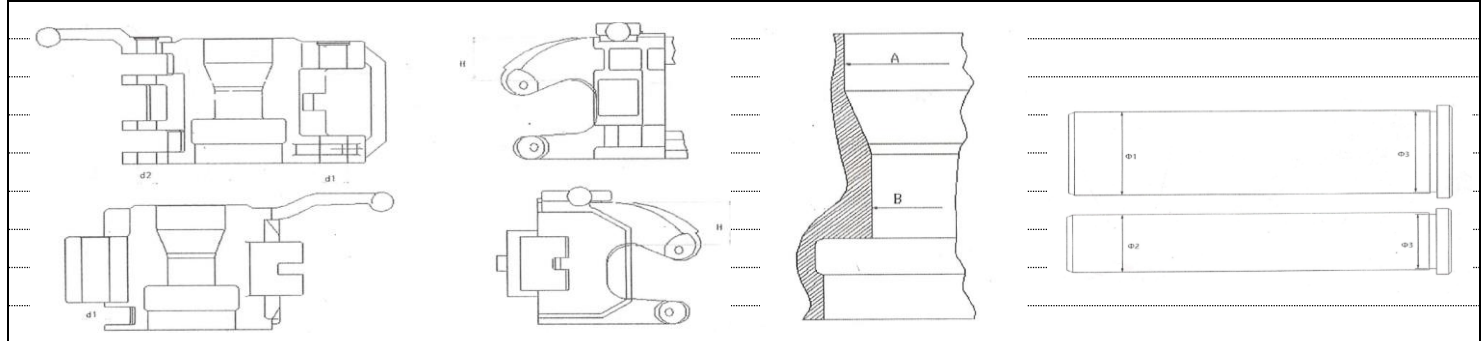

DESCRIPTION	ACTUAL VALUE	OEM VALUES	RESULT
Lifting Ear (H)	118.20 mm	116 mm	ACCEPT
Hinge Pin Hole (d1)	68.33 mm	68.67 mm	ACCEPT
Hinge Pin (Ø1)	67.50 mm	67.73 mm	ACCEPT
Latch Pin Hole (d2)	48.35 mm	48.53 mm	ACCEPT
Latch Pin (Ø2)	47.91 mm	47.73 mm	ACCEPT

**Remarks:**

CAT IV Inspection Was Carried Out on ELEVATOR D/P and Found Accepted at The Time of Inspection.

**Inspector:** Abdullah Mofed **Supervisor:** NAVEED HUSSIEN

**Customer Reprehensive**





### ELEVATOR 5 1/2" D/P CAT IV INSPECTION REPORT

<b>Customer:</b>	Daqing Drilling Company	<b>Date of inspection:</b>	29-05-2024
<b>Rig Name:</b>	Rig (DQ -037)	<b>Report No:</b>	QC-DQ-05-24-0171-11
<b>Type of Inspection:</b>	CAT IV Inspection.	<b>Specification:</b>	API RP 8B

### PICTORIAL



**Remarks:**

CAT IV Inspection Was Carried Out on ELEVATOR D/P and Found Accepted at The Time of Inspection.

**Inspector:** Abdullah Mofed

**Supervisor:** NAVEED HUSSIEN

**Customer Reprehensive**

