

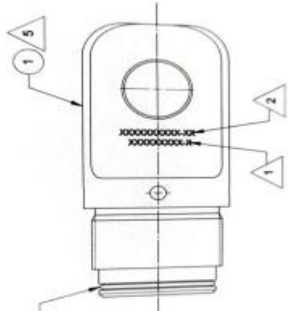
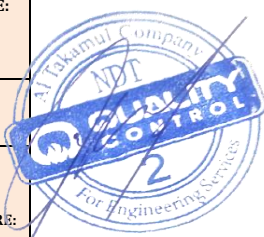
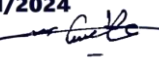

CERTIFICATION OF VISUAL, THOROUGH EXAMINATION & MAGNETIC PARTICLE INSPECTION

Client:	HALLIBURTON	Report No:	QC/24/HALL-WPS-08	
Location:	WPS	Job Number:	250124	
Date:	24.JANUARY.2024	Next Inspection Date:	23.JULY.2024	
Type Of Inspection:	VISUAL , THOROUGH EXAMINATION & MAGNETIC PARTICLE INSPECTION	Specification:	DS-1 Volume 4- 5th Edition Halliburton Doc. (Visual Procedure D00305796 Revision U) Halliburton Doc. (MPI Procedure D00976850 Revision D)	
 	UNIT DESCRIPTION:	LIFTING CAP (3 1/4 - 6 STUB ACME (3 5/8 DITS)) PIN		
	UNIT S/N:	DM4		
	UNIT SWL:	10000 LBS		
	INSPECTION RESULT :			
	VISUAL , THOROUGH EXAMINATION	unit fully inspected and found free from deforms, cracks, corrosion & mechanical damage		
	MAGNETIC PARTICLE INSPECTION	Welds & forgn areas inspected and found free from cracks and other defects		
FINAL RESULTS	unit found satisfactory and free of defects at the time of inspection			
COMMENT:				
Magnetic Particle Inspection With A/C Hand Yoke , Black & White Contrast				

EQUIPMENT DETAILS						PERSON DETAILS		REVIEW BY	
EQUIPMENT :	AC/DC Yoke PERMANET HAND MAGNATIC	EQUIPMENT :	Shooting Coil DC	EQUIPMENT :	UV BLACK LIGHT: 3140 μw/cm ²	INSPECTOR NAME: ASHRAF ELSAID		SENIOR INSPECTOR:	NAVEED HUSSAIN
S.NO:	201504048 USA PYO-019CM (PY-02)	S.NO:	22650	S.NO:	1932401			SUPERVISOR:	HANI ALI
Cal Due Date:	14.FEB.2024	Cal Due Date:	14.FEB.2024	Cal Due Date:	14.FEB.2024			CLIENT:	ALI Talib HB48903 Date: 25/01/2024 Signature:  Haliburton
FLUORESCENT 14HF	Magnaflux	Batch No:	220306	EXPIRE DATE:	MARCH,2025				
Whie Contrast Paint Manufacture:	Magnaflux	Batch No:	220602	EXPIRE DATE:	JUN,2025				
Digital Lux Meter WHITE LIGHT INTENSITY:	TECHNICAL DETAILS				Black Magnetic Ink Manufacture:7HF	STAMP & SIGNATURE:			
3350 Lux/S.NO:2722003	Wet FLUORESCENT Particle Concentration 14 HF		0.1 to 0.4 ml/100 ml		Batch No:220605				
16.FEB.2024	Black Magnetic Ink Concentration 7 HF		1.2 to 2.4 ml/100 ml		EXPIRE DATE:	Jul-25			