



Single Joint Elevator CAT IV Inspection Certificate

Customer:	Zhongman Petroleum and Natural Gas Group Corp. Ltd Iraq Branch	Date of Service:	11.01.2023
Department:	Casing team	Location:	ZPEC BASE
Report No:	QC-ZPEC-01-2024-0022/65	Specification:	API RP 8B

PROCEDURE

Quantity:	01 Set
Equipment Name:	Single Joint Elevator
Serial No:	120002
Modell & Size:	DDF4 ½”-5
Manufacturer:	JIANGSU RUI SHI
Standard:	API RP 8B
Frequency:	06 Month

The Rig was equipped with Single Joint Elevator the Following specification:

PROCEDURE

Single Joint Elevator was found fully installed condition for inspection. CAT IV Full inspection. Single Joint Elevator Inspection Was Conducted as Per Standard.

Visually check the Single Joint Elevator for any damage, missing parts or cracks.

Dismantle the Single Joint Elevator as for possible into single components.

Visually checked for damage, deformations or cracks on the hinge's brackets, Single Joint Elevator segments with tail slot handles and hinge pin.

Visual & MPI was carried out as per manufacture recommendation of hanged connection body (inside & outside) handles guide halves Single Joint Elevator top cover halves etc.

Measure the wear of the hinge connection door & pin hole dovetail etc.

check the conditions & the content of the name plate or stamped parts

Check the parts after reassembled & repainted

Prepare & submitted the inspection report.

**** Visual and MPI Was Carried Out on the Available Critical Areas of the Single Joint Elevator and Found Satisfactory for Further Use.**

**** CAT IV Inspection Was Carried Out on Single Joint Elevator and Found Satisfactory at The Time of Inspection.**

-The products have been examined and found them conformable to relevant Quality standards and delivery is thus permitted

Inspector:	Khaled Mahmoud	Supervisor:	Mohamed Abdalla
Customer Reprehensive			





Single Joint Elevator CAT IV Inspection Certificate

Customer:	Zhongman Petroleum and Natural Gas Group Corp. Ltd Iraq Branch	Date of Service:	11.01.2023
Department:	Casing team	Location:	ZPEC BASE
Report No:	QC-ZPEC-01-2024-0022/65	Specification:	API RP 8B

PROCEDURE

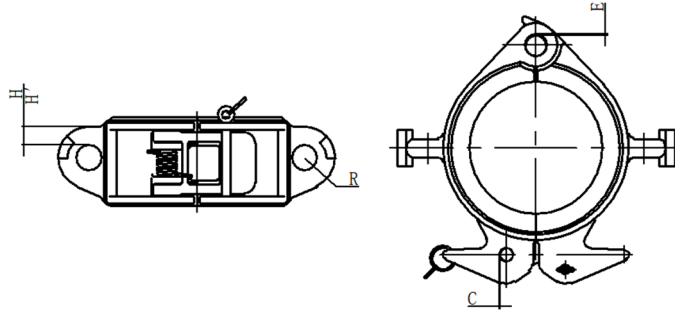

DESCRIPTION		VALUES	OEM VALUES	RESULT
Hinge axis	Maximum gap allowed E	0.38 mm	0.38 mm	Accept
	Minimum size of shaft pin design	19.61 mm	19.88 mm	Accept
	Maximum size of shaft hole design	20.01 mm	20.05 mm	Accept
	Maximum size of shaft hole wear	20.21mm	20.26 mm	Accept
stuck page axis	Maximum gap allowed F	0.38 mm	0.38 mm	Accept
	Minimum size of shaft pin design	17.81 mm	17.91 mm	Accept
	Maximum size of shaft hole design	18.01 mm	18.05 mm	Accept
	Maximum size of shaft hole wear	18.26 mm	18.29 mm	Accept
Lifting ears	Design wing diameter H	φ20 mm	φ20 mm	Accept
	Minimum wing diameter H	Φ17 mm	Φ17 mm	Accept
	Lifting ear radius R	15 mm	15 mm	Accept

Inspector:	Khaled Mahmoud	Supervisor:	Mohamed Abdalla
Customer Reprehensive			





Single Joint Elevator CAT IV Inspection Certificate

Customer:	Zhongman Petroleum and Natural Gas Group Corp. Ltd Iraq Branch	Date of Service:	11.01.2023
Department:	Casing team	Location:	ZPEC BASE
Report No:	QC-ZPEC-01-2024-0022/65	Specification:	API RP 8B

PICTORIAL



Inspector:	Khaled Mahmoud	Supervisor:	Mohamed Abdalla
Customer Reprehensive			

