



## Casing Slip CAT IV Inspection Certificate

Customer:	Zhongman Petroleum and Natural Gas Group Corp. Ltd Iraq Branch	Date of Service:	11.01.2023
Department:	Casing team	Location:	ZPEC BASE
Report No:	QC-ZPEC-01-2024-0022/41	Specification:	API RP 7L

### PROCEDURE

Quantity:	01 Set
Equipment Name:	Casing SLIP
Serial No:	150029
Size:	SDXL 3-1/2"
Manufacturer:	JIANGSU TAIXIN
Standard:	API RP 7L
Frequency:	06 Month

**The Rig was equipped with Casing Slip the Following specification:**

### PROCEDURE

**Casing Slip was found fully installed condition for inspection. CAT IV Full inspection.**

**Casing Slip Inspection Was Conducted as Per Standard.**

Visually check the slips for any damage, missing parts or cracks.

Dismantle the slips as for possible into single components.

Visually checked for damage, deformations or cracks on the hinge's brackets, slips segments with tail slot handles and hinge pin.

Visual & MPI was carried out as per manufacture recommendation of hanged connection body (inside & outside) handles guide halves slip top cover halves etc.

Measure the wear of the hinge connection door & pin hole dovetail etc. ....

check the conditions & the content of the name plate or stamped parts

Check the parts after reassembled & repainted

Prepare & submitted the inspection report.

**\*\* Visual and MPI Was Carried Out on the Available Critical Areas of the Casing SLIP and Found Satisfactory for Further Use.**

**\*\* CAT IV Inspection Was Carried Out on Casing SLIP and Found Satisfactory at The Time of Inspection.**

**-The products have been examined and found them conformable to relevant Quality standards and delivery is thus permitted**

<b>Inspector:</b>	Khaled Mahmoud	<b>Supervisor:</b>	Mohamed Abdalla
<b>Customer Reprehensive</b>			





## Casing Slip CAT IV Inspection Certificate

Customer:	Zhongman Petroleum and Natural Gas Group Corp. Ltd Iraq Branch	Date of Service:	11.01.2023
Department:	Casing team	Location:	ZPEC BASE
Report No:	QC-ZPEC-01-2024-0022/41	Specification:	API RP 7L

### PROCEDURE

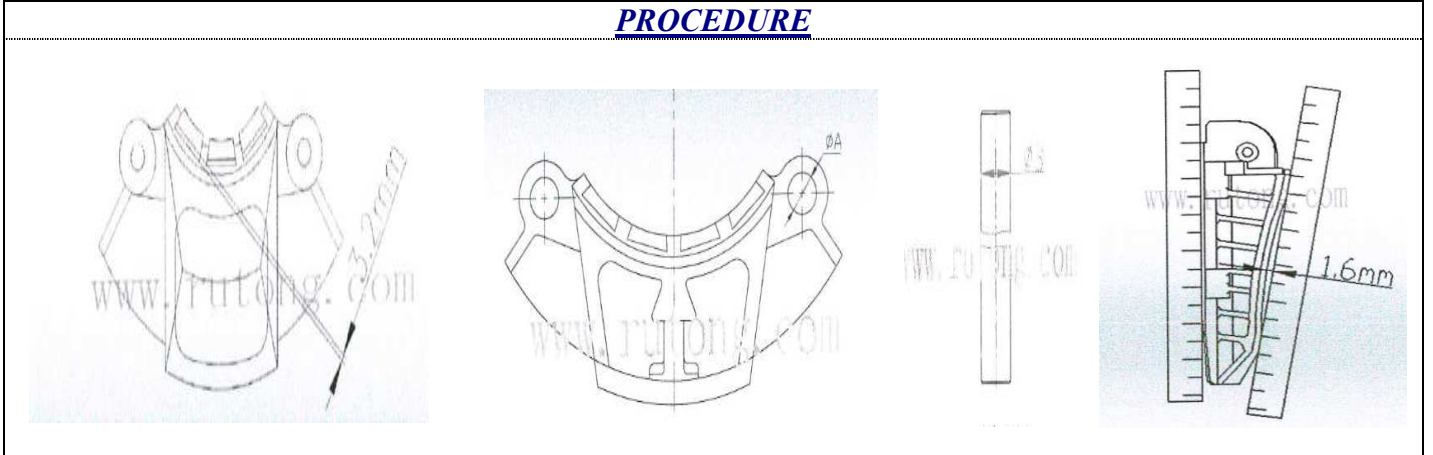

DESCRIPTION	VALUES	OEM VALUES	RESULT
The allowable maximum wear on the outside surface of the slips	0.3 mm	Max. 1.6 mm	ACCEPT
The maximum value of new hole "A"	16.95 mm	Min. 23 mm - Max. 24.5 mm	ACCEPT
The maximum clearance between hole and pin	1.90 mm	Max. 2 mm	ACCEPT
The maximum wear value of hole pin "B"	14.90 mm	Max. 21 mm -Min. 22 mm	ACCEPT

<b>Inspector:</b>	Khaled Mahmoud	<b>Supervisor:</b>	Mohamed Abdalla
<b>Customer Reprehensive</b>			





## Casing Slip CAT IV Inspection Certificate

Customer:	Zhongman Petroleum and Natural Gas Group Corp. Ltd Iraq Branch	Date of Service:	11.01.2023
Department:	Casing team	Location:	ZPEC BASE
Report No:	QC-ZPEC-01-2024-0022/41	Specification:	API RP 7L

### PICTORIAL

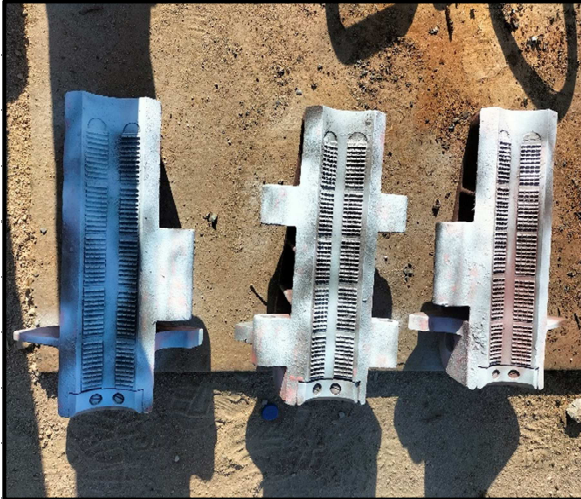

<b>Inspector:</b>	Khaled Mahmoud	<b>Supervisor:</b>	Mohamed Abdalla
<b>Customer Reprehensive</b>			

