

5" DRILL PIPE ELEVATOR CAT IV FULL INSPECTION CERTIFICATE

Customer:	Hong Hua Oil & Gas Engineering Services Limited	Date of Service:	10-11-2023	
Location:	ATS YARD	RIG No.:	HH-29	
Type Of Inspection:	CAT IV	P.O No.:	BY MAIL	
Report No.:	QC-2023-1541-H04	Speciation:	API RP 8B	

The rig was equipped with 5" Drill Pipe Elevator the Following specification:

Serial No	31110
Equipment Name	DRILL PIPE ELEAVTOR DDZ 5" EU- 350ton
Specification :	API RP 8B
Quantity :	01 Set
Manufacture :	2018-11
Frequency :	1 Year

-The products have been examined and found them conformable to relevant Quality standards and delivery is thus permitted

INSPECTION RESULT

**** Visual and MPI Was Carried Out On the Available Critical Areas of the 5" Drill Elevator and Found Satisfactory for Further Use.**

**** CAT IV Inspection Was Carried Out On 5" Drill Pipe Elevator and Found Satisfactory at The Time of Inspection.**

Remarks:

Detailed reports are attached detailing all readings and results in -01 of 04--- pages.

Inspector :	M.FAHAD	Supervisor:	WAQAS AWAN
Customer Reprehensive			

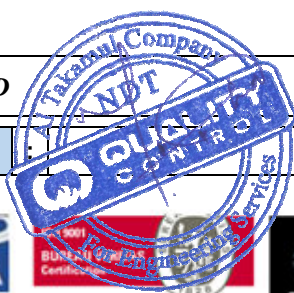

5" DRILL PIPE ELEVATOR CAT IV FULL INSPECTION CERTIFICATE

Customer:	Hong Hua Oil & Gas Engineering Services Limited	Date of Service:	10-11-2023	
Location:	ATS YARD	RIG No.:	HH-29	
Type Of Inspection:	CAT IV	P.O No.:	BY MAIL	
Report No.:	QC-2023-1541-H04	Speciation:	API RP 8B	

PROCEDURE

5" Drill Pipe Elevator was found fully installed condition for inspection. CAT IV Full inspection.

5" Drill Pipe Elevator Inspection Was Conducted as Per Standard.

- Full Cleaning by Buffing Brush the elevator to the qualified inspector's requirements.
- Measure the wear on the body parts, door, hinge pin, latch, latch pin, latch spring Stop, latch lock bolt, door lock pin, latch cam and all other load bearing Components and compare the measurements with the maximum wear Tolerances.
- MPI all of the above items as per the relevant API and manufacturer's manuals.
- For Y-type Elevators: check the slip visually, inserts, slip bolts, and insert retainers, Slip setting rings and guide plates for damage or wear.
- MPI the following items: slip elements, slip bolts, insert retainers and guide Plates.
- Measure clearance of hinge pin, latch pin and link ear thickness.
- Inspect the wire line of the single joint elevators for any damage, kinks etc.
- Measure bore taper angle, ID and height of center bore of type B and G Elevators, Measure ID and thickness of top and bottom bore of R, T and S type Elevators.
- Reassemble the elevator with new springs.
- Prepare and submit the inspection report.

Remarks:

Detailed reports are attached detailing all readings and results in -02 of 4--- pages.

Inspector :	M.FAHAD	Supervisor:	WAQAS AWAN
Customer Reprehensive			

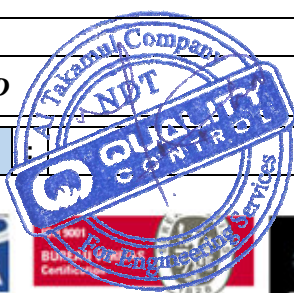

5" DRILL PIPE ELEVATOR CAT IV FULL INSPECTION CERTIFICATE

Customer:	Hong Hua Oil & Gas Engineering Services Limited	Date of Service:	10-11-2023	
Location:	ATS YARD	RIG No.:	HH-29	
Type Of Inspection:	CAT IV	P.O No.:	BY MAIL	
Report No.:	QC-2023-1541-H04	Speciation:	API RP 8B	

PROCEDURE

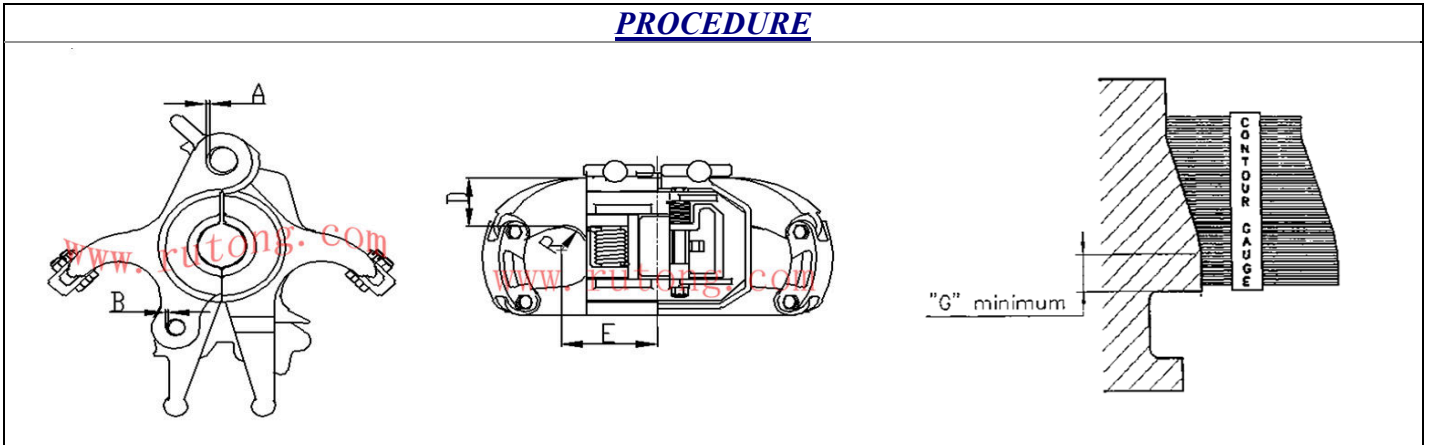

DESCRIPTION	ACTUAL VALUE	OEM VALUES MIN & MAX VALUE	RESULT
Lifting Ear (D)	124	116mm	Qualified
Hinge Pin Hole (A)	68.2	68.67mm	Qualified
Hinge Pin (A)	67.9	67.73mm	Qualified
The clearance A	0.5	1.143mm	Qualified
Latch Pin Hole (B)	48.2	48.53mm	Qualified
Latch Pin (B)	47.9	47.73mm	Qualified
The clearance B	0.6	0.889mm	Qualified
Hight (G)	64mm	45mm	Qualified
The distance (E)from the center	204mm	204mm	Qualified

Inspector :	M.FAHAD	Supervisor:	WAQAS AWAN
--------------------	----------------	--------------------	-------------------

Customer Reprehensive

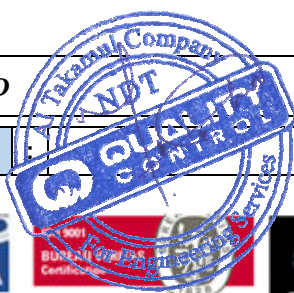

5" DRILL PIPE ELEVATOR CAT IV FULL INSPECTION CERTIFICATE

Customer:	Hong Hua Oil & Gas Engineering Services Limited	Date of Service:	10-11-2023	
Location:	ATS YARD	RIG No.:	HH-29	
Type Of Inspection:	CAT IV	P.O No.:	BY MAIL	
Report No.:	QC-2023-1541-H04	Speciation:	API RP 8B	



Inspector :	M.FAHAD	Supervisor:	WAQAS AWAN
Customer Reprehensive			





Visual & Magnetic Particles Examination Report

Client Name:	Hong Hua Oil & Gas Engineering Services Ltd.	Location:	HH Rig 029	Job Number:	QC-2023-1541
Date of Examination:	10-11-2023	Date of Report:	10-11-2023	Certificate No:	QC-2023-1541-H04
Serial Number	Description of the examined equipment				Result
31110	DRILL PIPE ELEAVTOR DDZ 5" EU- 350ton				Accepted



NDT Equipment Details

Standard	API RP 8B CAT-IV & ASTM E709	Viewing Condition:	Colored Media	Method	WET
Yoke	Permanent	Serial No:	PY-09	Due Date	16-02-2024
White Contrast	WCP-2	Batch No:	220602	Due Date	06-2025
Black Ink	7HF	Batch No:	220605	Due Date	7-1-2025

NDT procedure

Visual and MPI carried out for the above description and found free of surface defects at the time of inspection

Identification of any part found to have a defect and a description of the defect:

None

Particulars of any repair, renewal or alteration required to remedy the defect identified above:

None

ASNT Level II Inspector Name:	Signature & Stamp:	Date of Next Through Examination:
M. FAHAD		09-11-2024

REV: 01 Dated: 20 June 2022

