



## ELEVATOR LINK CAT IV FULL INSPECTION CERTIFICATE

<b>Customer:</b>	Daqing Drilling Company	<b>Date Of Service:</b>	09.04.2025
<b>Type Of Inspection:</b>	CAT III INSPECTION	<b>Report No:</b>	QC-B-04-25-0166-09
<b>Rig &amp; Location:</b>	DQ Rig 037	<b>Specification:</b>	API RP 8B

### PROCEDURE

<b>Equipment :</b>	<i>Elevator links</i>
<b>SN :</b>	<i>9069 , 9070</i>
<b>Ref Standard :</b>	<i>API RP 8B</i>



**The Rig Was Equipped with Elevator Links**

#### The Following Specification

<b>QTY</b>	<i>1 (set)</i>
<b>Manufacture:</b>	<i>N/A</i>
<b>Minimum Requirement Frequency Field Inspection (CAT IV) :</b>	<i>After SIX MONTH</i>
<b>SWL:</b>	<i>500TON</i>

**Remarks:**

*Detailed reports are attached detailing all readings and results in -01 of 05- pages.*

<b>LEE A &amp; ASNT Level II Inspector Name:</b>	<b>SIGNATURE:</b>	<b>Authenticating This Report:</b>	<b>SIGNATURE:</b>
Abdullah Mofeed		Mohammed Abdullah	





## ELEVATOR LINK CAT IV FULL INSPECTION CERTIFICATE

<b>Customer:</b>	Daqing Drilling Company	<b>Date Of Service:</b>	09.04.2025
<b>Type Of Inspection:</b>	CAT III INSPECTION	<b>Report No:</b>	QC-B-04-25-0166-09
<b>Rig &amp; Location:</b>	DQ Rig 037	<b>Specification:</b>	API RP 8B

### PROCEDURE

- **The Products Have Been Inspected and Found Them Conformable to Relevant**

The Rig was equipped with. *Elevator Links* with the following specification

- 01- Visually checked for the serial number.
- 02- Links Buffing & Cleaning Done as per the requirements of qualified inspector.
- 03- Visually checked for damage, deformations or cracks of the links
- 04- Visual & MPI checked for whole links, measured the eye thickness for wear.
- 05- Checked for the measure length & checked the straightness of the links.
- 06- Down grade the links as necessary according to the measured wear to the maximum Load limit.
- 07- Checked the parts after repainted.



### INSPECTION RESULT

**\*\* Visual & MPI was carried out on the available critical areas of the Elevator Links and found Accept at the time of inspection**

**\*\* CAT IV Inspection was carried out on An Elevator Links & found satisfactory for further use**

**Remarks:**

*Detailed reports are attached detailing all readings and results in -02 of 05- pages.*

<b>LEEA &amp; ASNT Level II Inspector Name:</b>	<b>SIGNATURE:</b>	<b>Authenticating This Report:</b>	<b>SIGNATURE:</b>
Abdullah Mofeed		Mohammed Abdullah	





## ELEVATOR LINK CAT IV FULL INSPECTION CERTIFICATE

<b>Customer:</b>	Daqing Drilling Company	<b>Date Of Service:</b>	09.04.2025
<b>Type Of Inspection:</b>	CAT III INSPECTION	<b>Report No:</b>	QC-B-04-25-0166-09
<b>Rig &amp; Location:</b>	DQ Rig 037	<b>Specification:</b>	API RP 8B

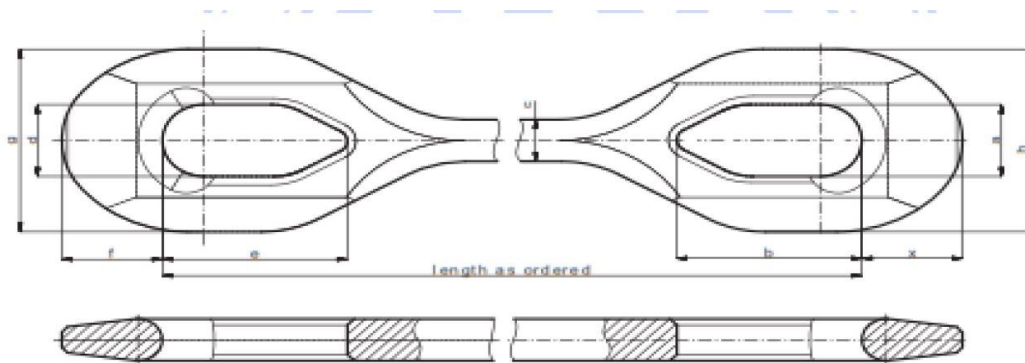

### PROCEDURE



Description	S.NO: 3341	S.NO: 3343	OEM Values	Result
	Actual Value	Actual Value		
UPPER LINK WEAR POINT(f)	6 2/10"	6 2/10"	6 1/16"	ACCEPT
LOWER LINK WEAR POINT(x)	3 18/32"	3 18/32"	3 1/2"	ACCEPT
OD(c)	4 3/4"	4 3/4"	4 1/2"	ACCEPT
DIMENSION(e)UPPER LINK	12"	12"	12 1/4"	ACCEPT
DIMENSION(b)LOWER LINK	10 1/8"	10 1/8"	10 1/4"	ACCEPT

**Remarks:**

*Detailed reports are attached detailing all readings and results in -03 of 05- pages.*

<b>LEE &amp; ASNT Level II Inspector Name:</b>	<b>SIGNATURE:</b>	<b>Authenticating This Report:</b>	<b>SIGNATURE:</b>
Abdullah Mofeed		Mohammed Abdullah	





## ELEVATOR LINK CAT IV FULL INSPECTION CERTIFICATE

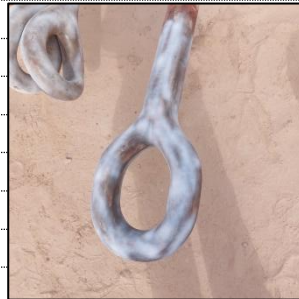

<b>Customer:</b>	Daqing Drilling Company	<b>Date Of Service:</b>	09.04.2025
<b>Type Of Inspection:</b>	CAT III INSPECTION	<b>Report No:</b>	QC-B-04-25-0166-09
<b>Rig &amp; Location:</b>	DQ Rig 037	<b>Specification:</b>	API RP 8B

### PROCEDURE



**Remarks:**

*Detailed reports are attached detailing all readings and results in -04 of 05- pages.*

<b>LEE A &amp; ASNT Level II Inspector Name:</b>	<b>SIGNATURE:</b>	<b>Authenticating This Report:</b>	<b>SIGNATURE:</b>
Abdullah Mofeed		Mohammed Abdullah	



## ELEVATOR LINK CAT IV FULL INSPECTION CERTIFICATE

<b>Customer:</b>	Daqing Drilling Company	<b>Date Of Service:</b>	09.04.2025
<b>Type Of Inspection:</b>	CAT III INSPECTION	<b>Report No:</b>	QC-B-04-25-0166-09
<b>Rig &amp; Location:</b>	DQ Rig 037	<b>Specification:</b>	API RP 8B

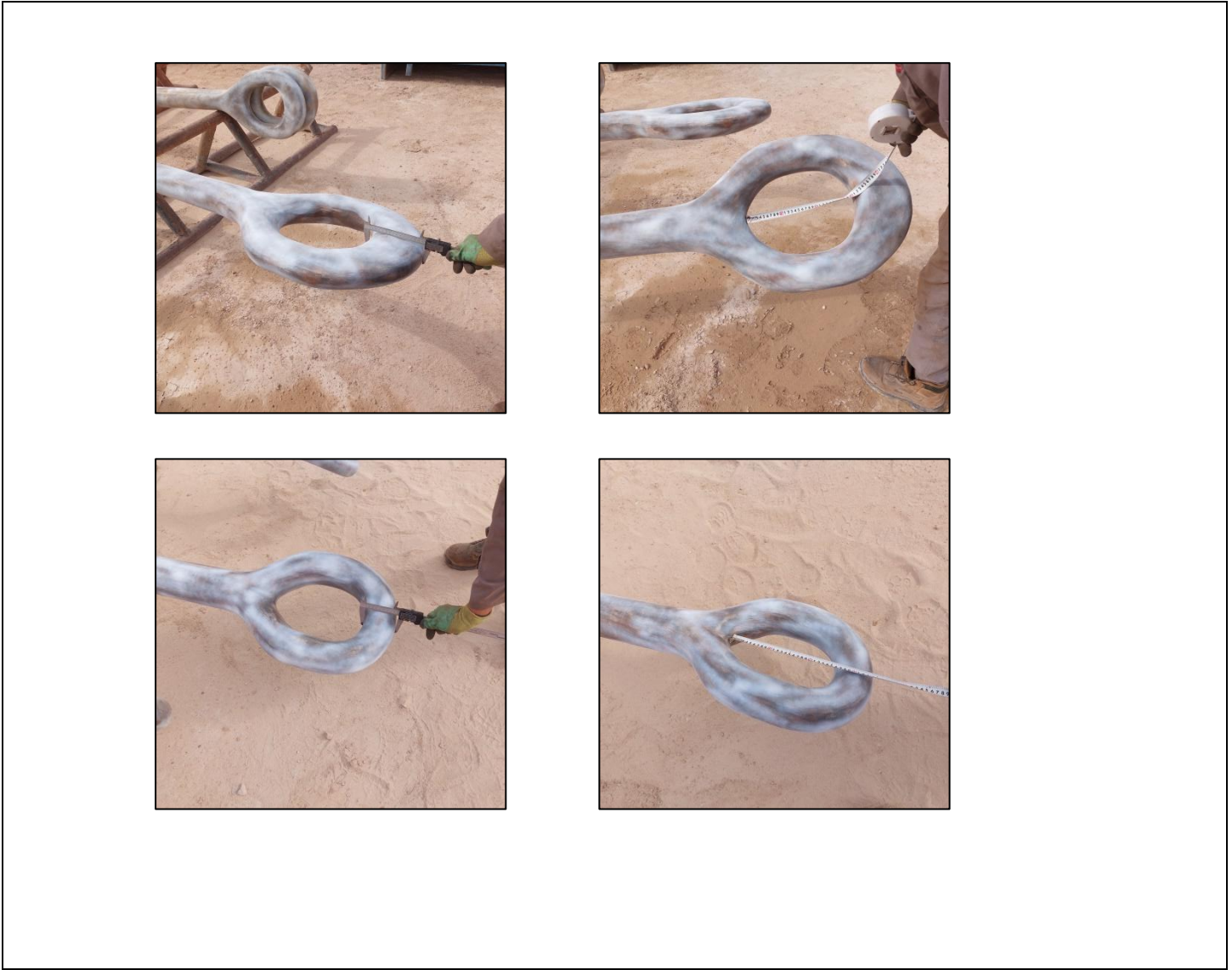

**Remarks:**  
*Detailed reports are attached detailing all readings and results in -05 of 05- pages.*

<b>LEE &amp; ASNT Level II Inspector Name:</b>	<b>SIGNATURE:</b>	<b>Authenticating This Report:</b>	<b>SIGNATURE:</b>
Abdullah Mofeed		Mohammed Abdullah	